



Visualisation; Diagnostics

Easy to Configure

Programming IEC 61131-3

Rapid Installation

PSSu K F EI CV(-T)

PILZ

THE SPIRIT OF SAFETY

► Decentralised system PSSuniversal I/O

This document is the original document.

All rights to this documentation are reserved by Pilz GmbH & Co. KG. Copies may be made for the user's internal purposes. Suggestions and comments for improving this documentation will be gratefully received.

Source code from third-party manufacturers or open source software has been used for some components. The relevant licence information is available on the Internet on the Pilz homepage.

Pilz®, PIT®, PMI®, PNOZ®, Primo®, PSEN®, PSS®, PVIS®, SafetyBUS p®, SafetyEYE®, SafetyNET p®, the spirit of safety® are registered and protected trademarks of Pilz GmbH & Co. KG in some countries.



SD means Secure Digital

Section 1	Introduction	6
	1.1	Validity of documentation 6
	1.1.1	Retaining the documentation 6
	1.1.2	Terminology: System environment A and B 6
	1.2	Definition of symbols 7
Section 2	Overview	8
	2.1	Module features 8
	2.2	Front view 9
Section 3	Safety	10
	3.1	Intended use 10
	3.2	Safety regulations 11
	3.2.1	Use of qualified personnel 11
	3.2.2	Warranty and liability 11
	3.2.3	Disposal 11
Section 4	Function description	12
	4.1	Module and periphery supply 12
	4.2	FS outputs 12
	4.2.1	Single-pole outputs 12
	4.2.2	Notes 14
	4.3	ST output 14
	4.4	Cascading 14
	4.5	Monitoring functions 16
	4.5.1	Safe speed monitoring - SSM 17
	4.5.2	Safe speed range monitoring - SSR-M 19
	4.5.3	Safe operating stop monitoring SOS-M 21
	4.5.4	Safe direction monitoring SDI-M 23
	4.5.5	Activation of safety function SS1 on a servo amplifier 25
	4.5.5.1	Reaction on SS1-M (a) 25
	4.5.5.2	Reaction on SS1-M (c) 27
	4.5.6	Activation of safety function STO on a servo amplifier 28
	4.6	Position counter value 28
	4.7	Integrated protection mechanisms 28
	4.8	Reaction times 29
	4.9	Configuration 29
	4.9.1	Access to I/O data 29
	4.10	Proximity switches 33
	4.11	Encoder 34
	4.11.1	Output signals 35
	4.11.2	Adapters for encoders 37
Section 5	Installation	38
	5.1	General installation guidelines 38
	5.1.1	Dimensions 38
	5.2	Install compact module 39

5.3	Install/uninstall connector	41
5.4	Install labelling bracket	42
Section 6	Wiring	43
6.1	Connectors' mechanical connection	43
6.2	Connect/disconnect the cables	44
6.3	Supply voltage	45
6.4	Connection of proximity switches	46
6.5	Connection of encoders	47
6.5.1	Connect encoder	48
6.5.2	Connect encoder with Z index	48
6.5.3	Connect encoder via an adapter	49
6.6	Connection of proximity switch and encoder	50
6.7	EMC-compliant wiring	51
6.8	Function test during commissioning	53
Section 7	Operation	54
7.1	Messages	54
7.2	Display elements	55
7.2.1	Display elements for module diagnostics	55
7.2.2	Display elements for input and output status	56
Section 8	Technical details	57
8.1	Safety characteristic data	60
Section 9	Supplementary data	62
9.1	Categories	62
9.1.1	Safety level	62
9.1.2	Safety functions	62
9.1.3	Safety-related characteristic data for operation with non-safety-related encoder without additional requirements	63
9.1.3.1	Permitted sensor types and output signals	63
9.1.3.2	Safety-related architecture	64
9.1.3.3	Achievable safety level	64
9.1.4	Safety-related characteristic data for operation with non-safety-related encoder with mechanical fault exclusion	64
9.1.4.1	Permitted sensor types and output signals	64
9.1.4.2	Safety-related architecture	65
9.1.4.3	Achievable safety level	65
9.1.5	Safety-related characteristic data for operation with non-safety-related encoder with diagnostics via the drive controller	66
9.1.5.1	Permitted sensor types and output signals	66
9.1.5.2	Requirements of the drive controller	66
9.1.5.3	Safety-related architecture	67
9.1.5.4	Achievable safety level	67
9.1.6	Safety-related characteristic data for operation with a safe encoder	67
9.1.6.1	Permitted sensor types and output signals	68

9.1.6.2	Safety-related architecture	68
9.1.6.3	Achievable safety level	68
9.1.7	Safety-related characteristic data for operation with a safe encoder with Z index	69
9.1.7.1	Permitted sensor types and output signals	69
9.1.7.2	Safety-related architecture	69
9.1.7.3	Achievable safety level	70
9.1.8	Safety-related characteristic data for operation with non-safety-related encoder and proximity switch	70
9.1.8.1	Permitted sensor types and output signals	70
9.1.8.2	Safety-related architecture	71
9.1.8.3	Achievable safety level	71
9.1.9	Safety-related characteristic data for operation with 2 proximity switches	72
9.1.9.1	Permitted sensor types and output signals	72
9.1.9.2	Safety-related architecture	72
9.1.9.3	Achievable safety level	73
Section 10	Order reference	74
10.1	Product	74
10.2	Accessories	74

1 Introduction

1.1 Validity of documentation

This documentation is valid for the products PSSu K F EI CV and PSSu K F EI CV-T. It is valid until new documentation is published.

This operating manual explains the function and operation, describes the installation and provides guidelines on how to connect the product.

1.1.1 Retaining the documentation

This documentation is intended for instruction and should be retained for future reference.

1.1.2 Terminology: System environment A and B

The PSSu system can be used in two different system environments. The module's application area is described in the chapter "Intended Use" of the manual.

The distinction is made between

- ▶ PSSu in system environment A
- ▶ PSSu in system environment B

The distinction is based on the application area of the PSSu system.

PSSu in system environment A may be used in the

- ▶ Decentralised system PSSu I/O
- ▶ **Not** in the automation system PSS 4000

PSSu in system environment B may be used in the

- ▶ Automation system PSS 4000, e.g. with
 - Decentralised system PSSu I/O with SafetyNET p
 - Control system PSSu PLC
 - Control system PSSu multi

The modules PSSu K F EI CV and PSSu K F EI CV(-T) are exclusively for use in system environment B (automation system PSS4000).

1.2 Definition of symbols

Information that is particularly important is identified as follows:



DANGER!

This warning must be heeded! It warns of a hazardous situation that poses an immediate threat of serious injury and death and indicates preventive measures that can be taken.



WARNING!

This warning must be heeded! It warns of a hazardous situation that could lead to serious injury and death and indicates preventive measures that can be taken.



CAUTION!

This refers to a hazard that can lead to a less serious or minor injury plus material damage, and also provides information on preventive measures that can be taken.



NOTICE

This describes a situation in which the product or devices could be damaged and also provides information on preventive measures that can be taken. It also highlights areas within the text that are of particular importance.



INFORMATION

This gives advice on applications and provides information on special features.

2 Overview

2.1 Module features

- ▶ Max. 4 modules in one PSSu system
- ▶ Monitoring of 1 axis
- ▶ Can be configured in PAS4000
- ▶ Measured value recorded by proximity switch or encoder
- ▶ Monitoring functions:
 - Safe speed monitoring (SSM)
 - Safe speed range monitoring (SSR-M)
 - Safe operating stop monitoring (SOS-M)
 - Safe direction monitoring (SDI-M)
- ▶ Recording of position counter value
- ▶ Analogue voltage (track S)
- ▶ 2 digital FS outputs
 - Semiconductor technology
 - Single-pole
 - Positive-switching
 - Current load capacity per output: 0,5 A
 - Short circuit-proof
 - Overload-proof
 - Free from feedback
- ▶ 1 digital ST output
 - Semiconductor technology
 - Single-pole
 - Positive-switching
 - Short circuit-proof
 - Current load capacity per output: 0.5 A
- ▶ 1 combined ST input and output "CIO" for networking several devices
- ▶ LEDs for:
 - Switch status of each input/output
 - Module error
 - Module status
- ▶ For failsafe applications in system environment B (automation system PSS 4000)

Accessories:

- ▶ Connector with spring-loaded terminals (necessary for operation)
- ▶ Labelling bracket
- ▶ Labelling strips (sheets)

- ▶ T-type:
 - PSSu K F EI CV-T: for increased environmental requirements

2.2 Front view

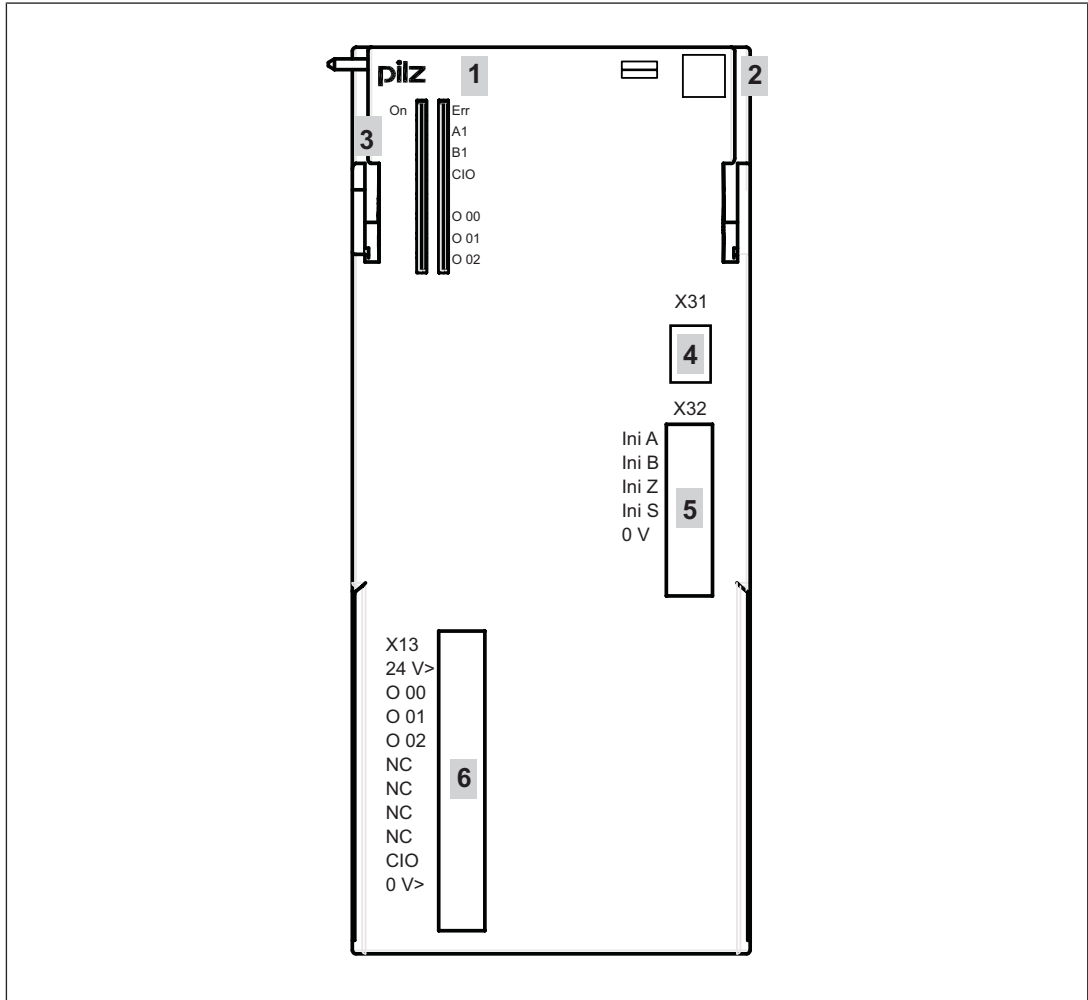

Legend:

- ▶ 1: Name of compact module
- ▶ 2: Labelling strip with:
 - 2D code
 - Order number
 - Serial number
 - Hardware version number
- ▶ 3: LEDs for status display and module diagnostics
- ▶ 4: Mini-IO socket X31 for connecting encoders
- ▶ 5: Connector strip X32 for connecting proximity switches
- ▶ 6: Connector strip X13 for connectors with spring-loaded terminals and labelling strip

3 Safety

3.1 Intended use

The module may be used for failsafe applications in system environment B (automation system PSS 4000).

- ▶ The module monitors safety functions in accordance with EN 61800-5-2 for safe motion monitoring.

The module performs the following monitoring functions:

- Safe Speed Monitoring (SSM)
- Safe Speed Range Monitoring (SSR-M)
- Safe Operating Stop Monitoring (SOS-M)
- Safe Direction Monitoring (SDI-M)

In accordance with EN ISO 13849-1 up to PL e and EN IEC 62061 up to SIL CL 3.

The module may only be used to monitor safety functions when the following blocks are used:

- FS_EI_Basic
 - FS_EI_SSM0
 - FS_EI_SOSM
 - FS_EI_SDIM
 - FS_EI_SSM1_SSRM
- ▶ In the "FS_I_EI_CV" data type, the module provides a safe position counter value in accordance with EN ISO 13849-1 up to PL d and EN IEC 62061 up to SIL CL 2.

The modules PSSu K F EI CV and PSSu K F EI CV-T may be used as safety components in accordance with the Lifts Directive 95/16/EC in accordance with the requirements of EN 81-1/2:1998+A3:2009, EN 81-20:2015, EN 81-50:2015, EN 81-22:2014 and EN 115-1:2008+A1:2010.

The programmable safety system should be installed in a protected environment that meets at least the requirements of pollution degree 2. Example: Protected inside space or control cabinet with protection class IP54 and corresponding air conditioning.

Intended use includes making the electrical installation EMC-compliant. Please refer to the guidelines stated in the "PSSuniversal Installation Manual". The module is designed for use in an industrial environment. It is not suitable for use in a domestic environment, as this can lead to interference.

The following is deemed improper use in particular:

- ▶ Any component, technical or electrical modification to the module
- ▶ Use of the module outside the areas described in this manual
- ▶ Any use of the module that is not in accordance with the technical details.

**INFORMATION**

The module PSSu K F EI CV is supported by PAS4000 from Version 1.15.0. The module PSSu K F EI CV-T is supported by PAS4000 from Version 1.16.0. We recommend that you always use the latest version (Download from www.pilz.de).

The module PSSu K F EI CV-T is suitable for use where there are increased environmental requirements (see Technical Details).

3.2 Safety regulations

3.2.1 Use of qualified personnel

The products may only be assembled, installed, programmed, commissioned, operated, maintained and decommissioned by competent persons.

A competent person is a qualified and knowledgeable person who, because of their training, experience and current professional activity, has the specialist knowledge required. To be able to inspect, assess and operate devices, systems and machines, the person has to be informed of the state of the art and the applicable national, European and international laws, directives and standards.

It is the company's responsibility only to employ personnel who

- ▶ Are familiar with the basic regulations concerning health and safety / accident prevention,
- ▶ Have read and understood the information provided in the section entitled Safety
- ▶ Have a good knowledge of the generic and specialist standards applicable to the specific application.

3.2.2 Warranty and liability

All claims to warranty and liability will be rendered invalid if

- ▶ The product was used contrary to the purpose for which it is intended,
- ▶ Damage can be attributed to not having followed the guidelines in the manual,
- ▶ Operating personnel are not suitably qualified,
- ▶ Any type of modification has been made (e.g. exchanging components on the PCB boards, soldering work etc.).

3.2.3 Disposal

- ▶ In safety-related applications, please comply with the mission time T_M in the safety-related characteristic data.
- ▶ When decommissioning, please comply with local regulations regarding the disposal of electronic devices (e.g. Electrical and Electronic Equipment Act).

4 Function description

4.1 Module and periphery supply

Module supply

- ▶ The module supply provides the module with voltage.

Periphery supply

- ▶ The periphery supply that supplies the outputs must be fed externally. The single-pole outputs must have a common supply voltage.

4.2 FS outputs

4.2.1 Single-pole outputs

- ▶ 2 single-pole digital outputs

Output test

- ▶ Outputs that are switched on are checked via regular off tests.
 - Test pulses for outputs that are switched on: see [Technical details \[57\]](#)
 - Outputs that are switched on are switched off for the duration of the test pulse.
 - The load must not switch off because of the test.
- ▶ Outputs that are switched off are checked via regular on tests.
 - Test pulses for outputs that are switched off: see [Technical details \[57\]](#)
 - Outputs that are switched off are switched on for the duration of the test pulse.
 - The load must not switch on because of the test.

Excluding individual outputs from the output test:

- ▶ If a plant is particularly sensitive to the test pulses, the output test may be switched off for individual outputs.
- ▶ The test must be replaced by other measures, depending on the safety requirement.
- ▶ When test pulses are switched off:
 - The correct switch status is always checked.
 - The output's ability to switch will not be detected until the next time the output is switched on/off.

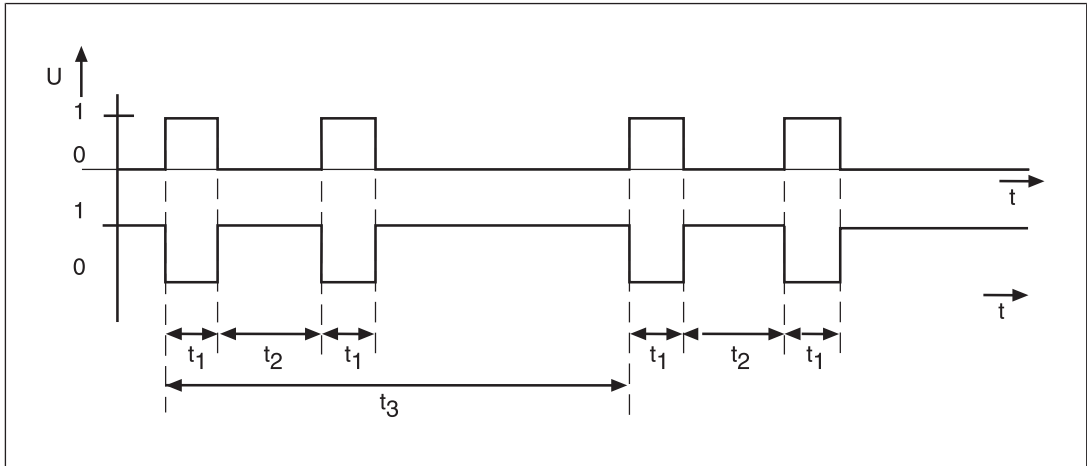

Fig.: On and off test for single-pole outputs

Legend

t_1 Pulse duration of on/off test (200 μ s)

t_2 Max. waiting time between the on/off test (approx. 4 ms)

t_3 Repetition time of on and off test in normal circumstances (approx. 2 s)

Characteristic for single-pole outputs: Output capacitance C dependent on load current I

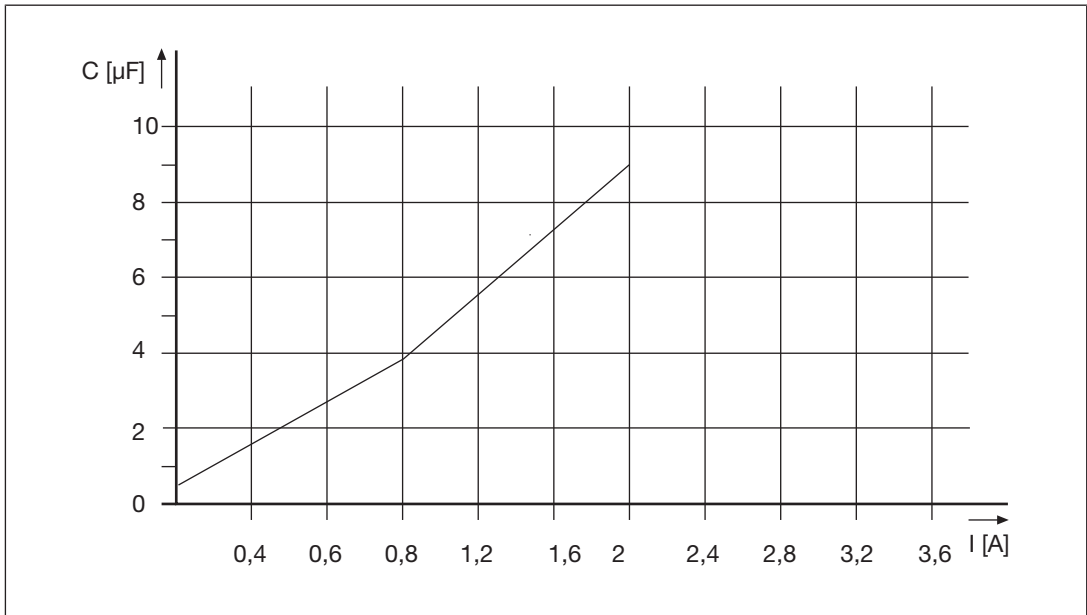

4.2.2 Notes



WARNING!

When wiring an output with capacitance it is essential to note the pulse duration, repetition period and scan time of the power-up test, otherwise the load may switch on unintentionally.

- ▶ For applications in accordance with Category 4, PL e and SIL 3, detection of shorts between contacts must be guaranteed either via the on/off test or through other measures (e.g. asynchronous switching). A short between contacts must be simulated during commissioning.

4.3 ST output

- ▶ 1 ST output

Signals at the output

- ▶ "0" signal (0 V) at the output:
 - Output is high impedance
 - No current to the load
- ▶ "1" signal (+24 V) at the output:
 - Output is low impedance
 - Current is supplied to the load

4.4 Cascading

Cascading can be used to network several modules. A combined standard input/output CIO is used for cascading. If one of the networked modules triggers a monitoring function, then all networked modules are switched off. To ensure that more than one axis can be stopped via cascading when a monitoring function reacts, the following measures are necessary:

- ▶ Connect the CIO terminals of all modules, whose axes are to be stopped at the same time. Make sure that the modules are connected to a common 0 V periphery supply.
- ▶ Activate the cascading input (terminal CIO) in the module's hardware configuration (PAS4000) if the module is to be switched off by another module via the cascading output CIO (repeat for other axes if applicable).
- ▶ Activate the cascading output (terminal CIO) with *ActivateCascading* = TRUE for all the modules connected via the terminals CIO.



NOTICE

All networked modules must be connected to a common 0 V periphery supply.

**CAUTION!**

Potential loss of safety function due to the use of cascading for safety-related applications

Depending on the application, serious injury or death may result. Cascading should only be used to network additional modules.

Example:

- ▶ Three axes are to be monitored.
- ▶ One module is used per axis:
 - Axis 1 = Module 1
 - Axis 2 = Module 2
 - Axis 3 = Module 3
- ▶ If a monitoring function has reacted at axis 1 or axis 2, then axis 3 is to be stopped.
- ▶ Wiring:
 - Connect together the CIO terminals of all modules, whose axes are to be stopped at the same time. Make sure that the modules are connected to a common 0 V periphery supply.
- ▶ Configuration:
 - Set the I-variable *ActivateCascading* to TRUE for module 1, module 2 and module 3 on the block FS_EI_Basic. This means that the result of the monitoring functions will affect the cascading output CIO of module 1 and module 2.
 - In the hardware configuration, the "Activate cascading input" option must be set to "Yes" for module 3. This means that the result of the monitoring functions from module 1 and module 2 will affect the cascading input CIO of module 3. If a monitoring function should react on module 1 or module 2, axis 3 monitored using module 3 will be stopped.

4.5 Monitoring functions

- ▶ The module's FS outputs can trigger the safety function STO or SS1 on a drive as a reaction to the result of the monitoring functions.
- ▶ The module's ST output can trigger the braking ramp of the safety function SS1 as a reaction to the result of the monitoring functions.
- ▶ The outputs have a restart interlock.
- ▶ The blocks can be used to deactivate unneeded monitoring functions.
- ▶ All monitoring functions that are not deactivated affect the outputs, along with cascading.

Further information is available in PAS4000's online help.

Function diagram:

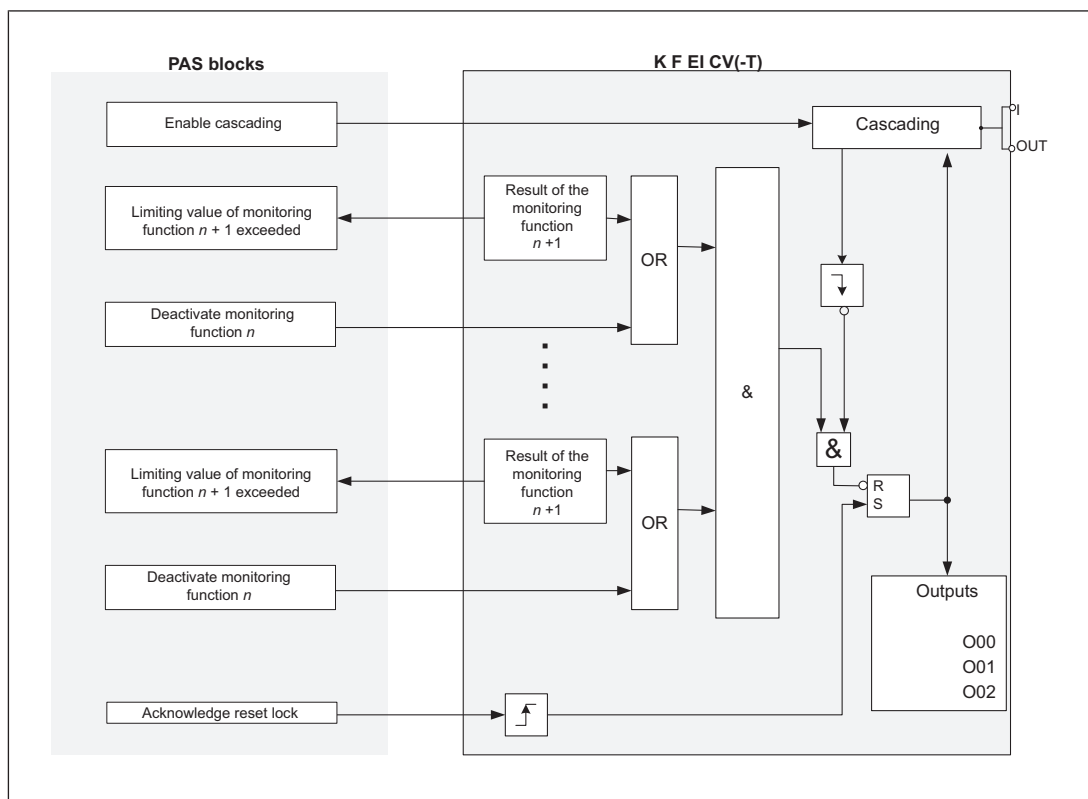

4.5.1 Safe speed monitoring - SSM

The "Safe speed monitoring" function (SSM) monitors whether the current speed exceeds a limit value.

A tolerance range may also be set for the limit values used to monitor the speed. This tolerance range modifies the set limit values. As a result, one-off or periodic overshoots that exceed the limit values can be tolerated.

Activate the monitoring function by:

- ▶ The monitoring function does not need to be activated. Monitoring starts as soon as the module is ready for operation.

Reaction:

- ▶ If the configured limit value, plus the configured tolerance, is violated:
 - a 1/0 pulse edge at SSM_Enable
 - the local outputs switch off, depending on the configuration. Further information is available in PAS4000's online help.

The following values can be configured for the tolerance range:

- ▶ Tolerance time (t1), which takes into account the length of the overshoots (maximum time for which the limit value may be exceeded)
- ▶ Tolerance period (t2), which takes into account the oscillation period (minimum time that must elapse between one limit value overshoot and the next)
- ▶ Tolerance amount as % (Tol), which takes into account the amplitude of the overshoots (maximum permitted percentage by which the configured limit values may be exceeded)
- ▶ Hysteresis as % (Hys), prevents the outputs from bouncing if there are fluctuations around the response value. The hysteresis takes effect when the output is switched on:
 - Switch-on value = Switching threshold – Hysteresis

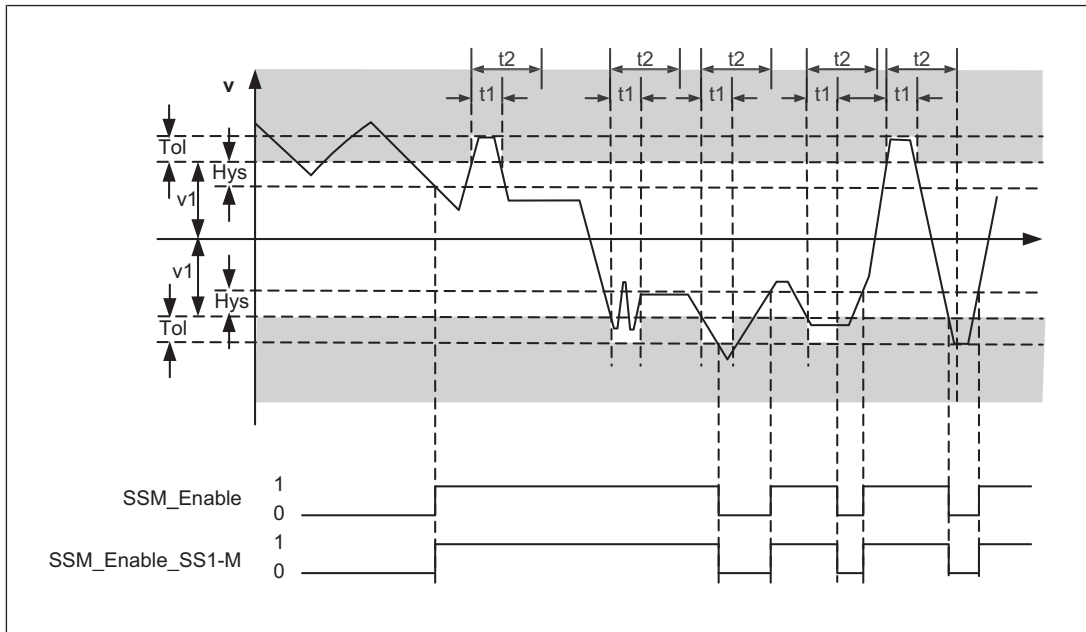
**Legend:**

- ▶ **SSM_Enable:**
 - "1": Monitored limit value is not violated
 - "0": Monitored limit value is violated
- ▶ **Output on the module (SSM_Enable_SS1):**
 - "1": Monitored limit value is not violated
 - "0": Monitored limit value is violated
- ▶ t_1 : Tolerance time
- ▶ t_2 : Tolerance period
- ▶ Tol (%): Tolerance amount of limit value in both directions
- ▶ Hys (%): Hysteresis when switching the monitoring function back on

4.5.2 Safe speed range monitoring - SSR-M

The "Safe Speed Range Monitoring" function (SSR-M) monitors the current speed to ensure it stays within a maximum and minimum permitted limit value.

A tolerance range may also be set for the limit values used to monitor the speed range. This tolerance range modifies the set limit values. As a result, one-off or periodic overshoots that exceed the range limits can be tolerated.

Activate the monitoring function by:

- ▶ The monitoring function does not need to be activated. Monitoring starts as soon as the module is ready for operation.

Reaction:

- ▶ If the configured limit value, plus the configured tolerance, is violated:
 - a 1/0 pulse edge at SSR_Enable
 - the local outputs switch off, depending on the configuration. Further information is available in PAS4000's online help.

The following values can be configured for the tolerance range:

- ▶ Tolerance time (t1), which takes into account the length of the overshoots (maximum time for which the limit value may be exceeded)
- ▶ Tolerance period (t2), which takes into account the oscillation period (minimum time that must elapse between one limit value overshoot and the next)
- ▶ Tolerance amount as a % (Tol), which takes into account the amplitude of the overshoots (maximum permitted percentage by which the limit value may be exceeded)
- ▶ Hysteresis as % (Hys), prevents the outputs from bouncing if there are fluctuations around the response value. The hysteresis takes effect when the output is switched on:
 - Switch-on value = Switching threshold – Hysteresis
- ▶ For the lower range limit:
 - Switch-on value = Switching threshold + Hysteresis

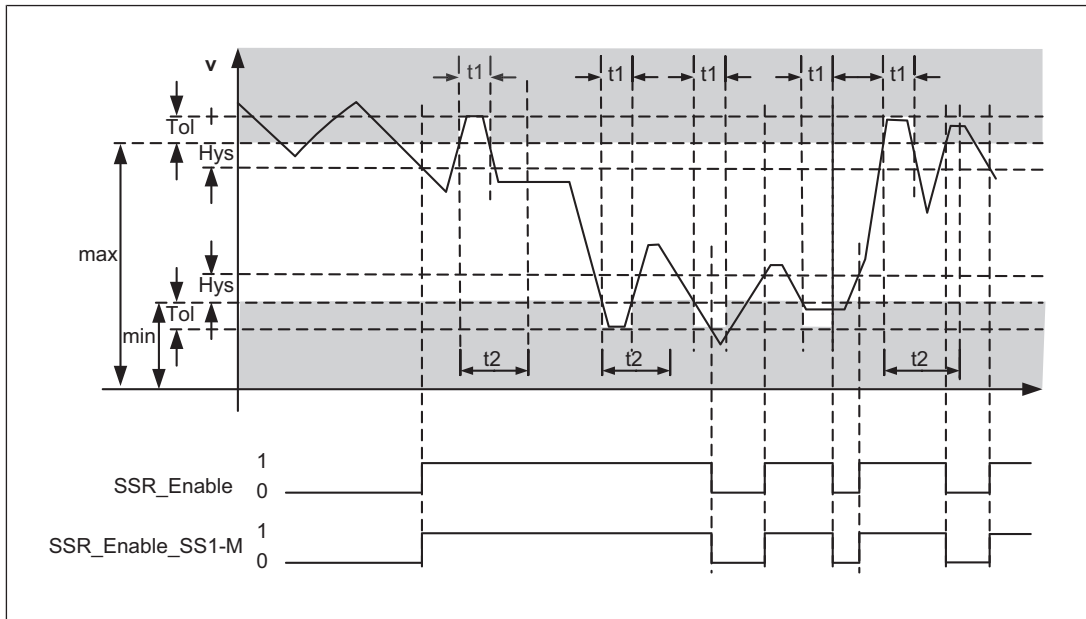
**Legend:**

- ▶ **SSR_Enable:**
 - "1": Monitored limit value is not violated
 - "0": Monitored limit value is violated
- ▶ **Output on the module (SSR_Enable_SS1-M):**
 - "1": Monitored limit value is not violated
 - "0": Monitored limit value is violated
- ▶ t_1 : Tolerance time
- ▶ t_2 : Tolerance period
- ▶ Tol (%): Tolerance amount of the two limit values, maximum and minimum speed
- ▶ Hys (%): Hysteresis when switching the monitoring function back on

4.5.3 Safe operating stop monitoring SOS-M

The "Safe Operating Stop Monitoring" function (SOS-M) monitors whether the standstill position remains within a configured tolerance window. The monitoring function SOS-M is not available on sensors on which a position cannot be determined (Ini pnp-pnp, pnp-npn, npn-pnp, npn-npn). The signals SOSM_Enable and SOSM_Enable_SS1M are constantly "0".

Activate the monitoring function by:

- ▶ 0/1 pulse edge at SetSOSM. The signal determines the current position to be monitored.

Reaction:

- ▶ 0/1 pulse edge at SOS-M_Enable_SS1-M
- ▶ SOS delay time (t1) is running
- ▶ A 0/1 pulse edge at SetSOSM before the delay time has elapsed is ignored.
- ▶ Once the SOS delay time has elapsed, the current position is adopted and safe standstill is monitored → 0/1 pulse edge at SOSM_Enable.
- ▶ Another 0/1 pulse edge at SetSOSM during active monitoring (SOSM_Enable = 'TRUE') means that the current position is immediately adopted as the new reference position, without delay.
- ▶ When the configured tolerance window is violated:
 - a 1/0 pulse edge at SOSM_Enable
 - the local outputs switch off, depending on the configuration. Further information is available in PAS4000's online help

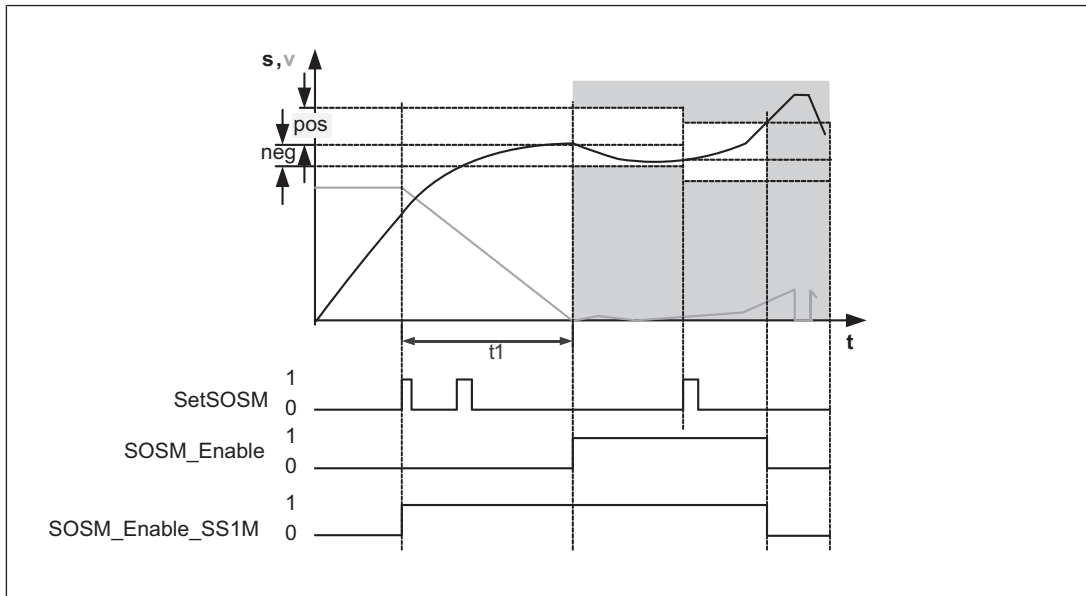

Legend

- ▶ **SetSOSM:** Adopt reference position once the delay time has expired
- ▶ **SOSM_Enable:**
 - "1": Monitored limit value not violated/monitoring of standstill position
 - "0": Monitored limit value violated/monitoring inactive
- ▶ **Output on the module (SOSM_Enable_SS1-M):**
 - "1": Monitored limit value not violated/monitoring of standstill position
 - "0": Monitored limit value violated/monitoring inactive
- ▶ **t1:** Delay time

4.5.4 Safe direction monitoring SDI-M

The "Safe Direction Monitoring" function (SDI-M) monitors the defined direction of movement of the drive axis (positive or negative). The monitoring function SDI-M is not available on sensors on which a position cannot be determined (Ini pnp-pnp, pnp-npn, npn-pnp, npn-npn). The signals SDIM_PosEnable (SDIM_NegEnable) and SDIM_PosEnable_SS1M (SDIM_NegEnable_SS1M) are constantly "0".

Activate the monitoring function by:

- ▶ The monitoring function does not need to be activated. Monitoring starts as soon as the module is ready for operation.

Reaction:

- ▶ If the respective direction, plus the configured tolerance, is violated:
 - a 1/0 pulse edge at SDIM_PosEnable or SDIM_NegEnable
 - the local outputs switch off, depending on the configuration. Further information is available in PAS4000's online help.
- ▶ If the monitored direction of movement has been violated and the current position moves in the right direction by more than the corresponding tolerance, SDIM_PosEnable (SDIM_NegEnable) is automatically reset to "1".
- ▶ If the monitored direction of movement has been violated and the current position cannot be moved in the right direction by at least the corresponding tolerance, then the monitoring function can be reset to "1" by a 0/1 pulse edge at SetSDIM.

Renewed adoption of the reference position or reactivation of the monitoring function:

- ▶ 0/1 pulse edge at SetSDIM

Monitoring of positive direction of movement:

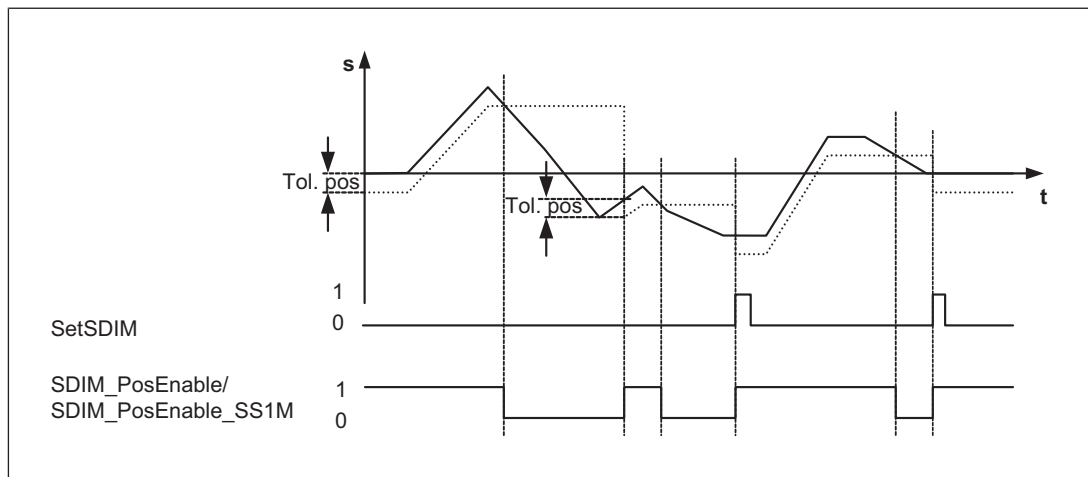

Monitoring of negative direction of movement:

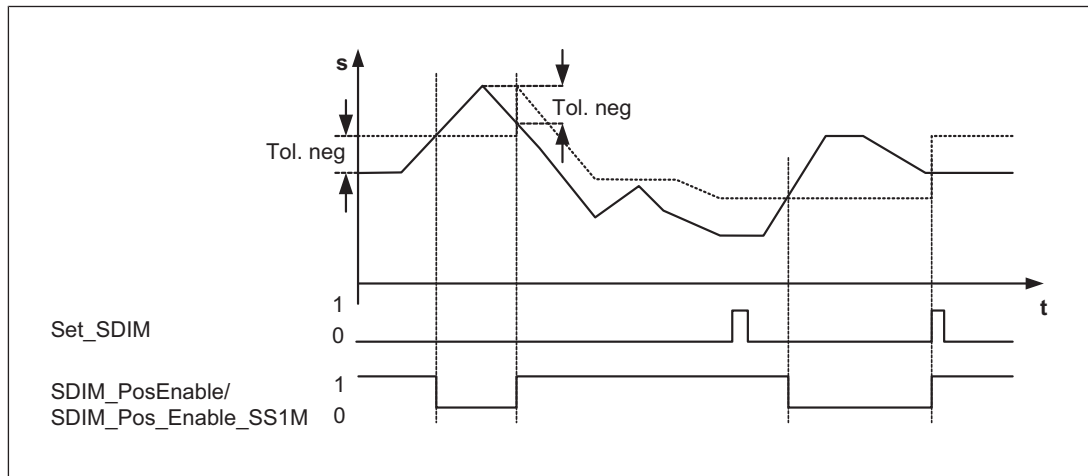

Legend:

- ▶ SDIM_PosEnable/SDIM_NegEnable:
 - "1": Monitored direction is not violated
 - "0": Monitored direction is violated
- ▶ Tol. pos/Tol. neg: Tolerance value, for which a movement contrary to the monitored direction will be accepted.

4.5.5 Activation of safety function SS1 on a servo amplifier

The safe outputs can be configured in such a way that they can activate the safety function SS1 (a and c) on a servo amplifier.

Activation of monitoring function:

- ▶ The "Activate outputs" option must be activated in PAS4000. In this case, the monitoring function affects the outputs on the module directly if a limit value is violated.
- ▶ At least one monitoring function must be activated for the FS outputs. The monitoring functions are activated by setting the O-data type "...DeactivateSS1M" to FALSE.

Activation:

- ▶ A monitoring function violates a monitored limit value and sets the restart interlock to "0".
or
- ▶ The user program sets the O-data types (ST_O_DO and FS_O_DO) to "0".

4.5.5.1 Reaction on SS1-M (a)

- ▶ The ST output O00 is shut down immediately.
- ▶ The FS outputs are shut down,
 - if the speed drops below a configured standstill limit value for the automatic STO
 - or
 - after a configured delay time has elapsed (STO delay time). The delay time starts running with a 1/0 pulse edge at the signal for the restart interlock or at the signal for the FS-O data types.
- ▶ If the delay time has elapsed and the signal for the restart interlock or FS-O data types is "0", then the assigned output is set to "0".
- ▶ If the delay time has elapsed and the signal for the restart interlock or FS-O data types is "1", then the assigned output remains at "1".
- ▶ If the delay time is running and another 1/0 pulse edge arrives at the signal for the restart interlock or FS-O data types, then the delay time is restarted.

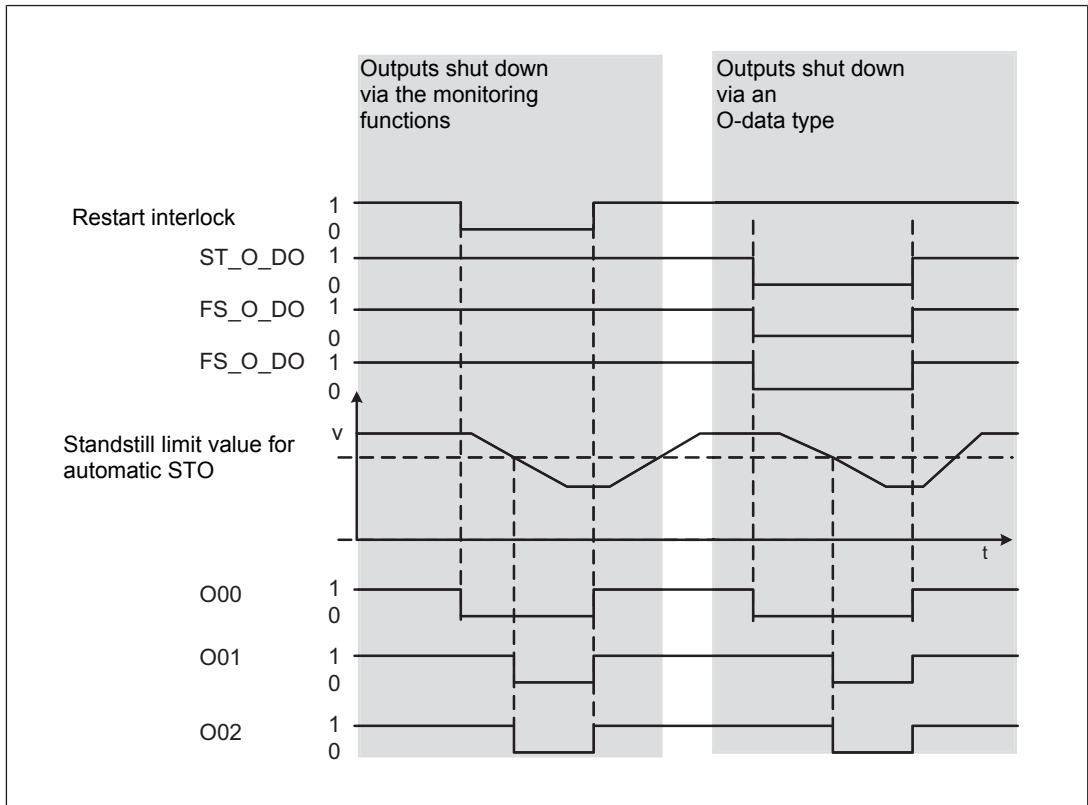

Legend:

- ▶ Restart interlock
- ▶ ST_O_DO: O-data type for the ST output
- ▶ FS_O_DO: O-data type for the FS output
- ▶ Standstill limit value for the automatic STO: Limit value for shutting down the outputs
- ▶ O00: ST output
- ▶ O01: FS output that can be used to trigger the STO function on a connected drive.
- ▶ O02: FS output that can be used to trigger the STO function on a connected drive.

4.5.5.2 Reaction on SS1-M (c)

- ▶ The ST output O00 is shut down immediately.
- ▶ The FS outputs are shut down after a configured delay time (STO delay time) has elapsed. The delay time starts running with a 1/0 pulse edge at the signal for the restart interlock or at the signal for the FS-O data types.
 - If the delay time has elapsed and the signal for the restart interlock or FS-O data types is "0", then the assigned output is set to "0".
 - If the delay time has elapsed and the signal for the restart interlock or FS-O data types is "1", then the assigned output remains at "1".
 - If the delay time is running and another 1/0 pulse edge arrives at the signal for the restart interlock or FS-O data types, then the delay time is restarted.

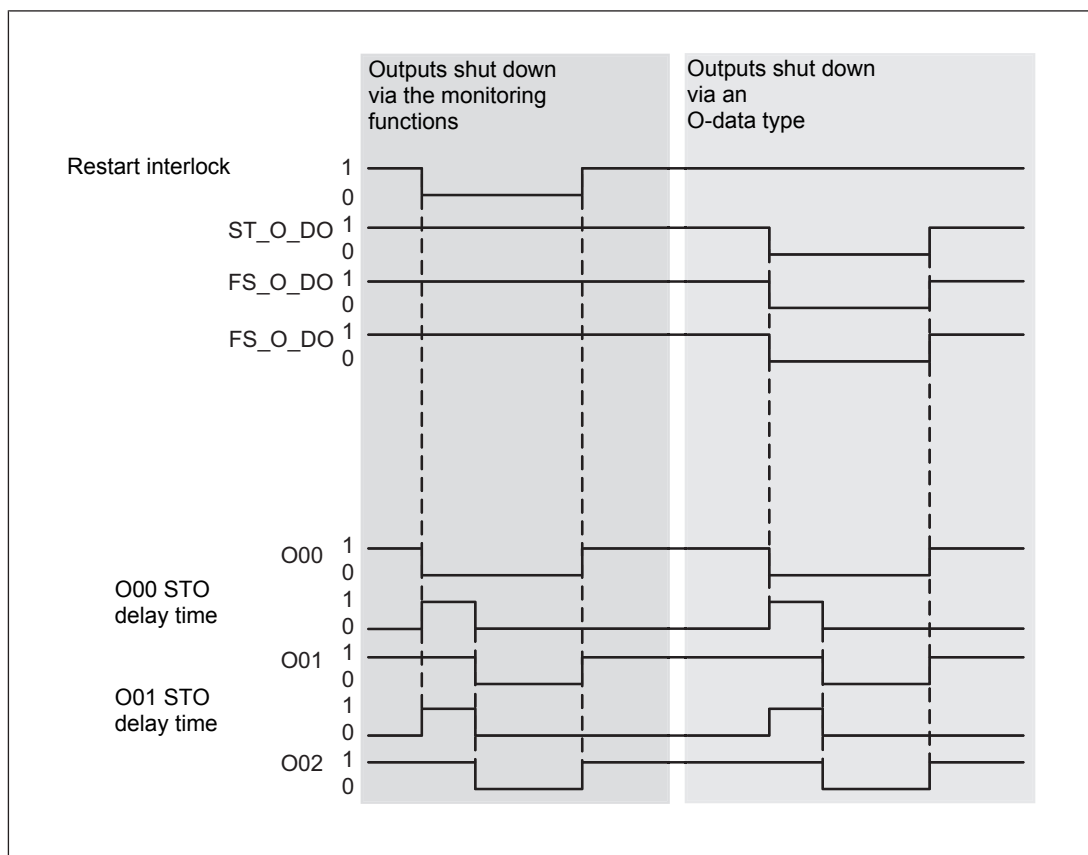

Legend:

- ▶ Restart interlock
- ▶ ST_O_DO: O-data type for the ST output
- ▶ FS_O_DO: O-data type for the FS output
- ▶ O00: ST output
- ▶ STO delay time: Delay time for shutting down the FS outputs
- ▶ O01: FS output that can be used to trigger the STO function on a connected drive.
- ▶ O02: FS output that can be used to trigger the STO function on a connected drive.

4.5.6 Activation of safety function STO on a servo amplifier

The module provides all the necessary functions to implement the safety function STO on a servo amplifier.

Features:

- ▶ The FS outputs O01 and O02 are used to activate the safety function STO on a servo amplifier.
- ▶ The configurable STO delay time must be deactivated in PAS4000 by entering a value of 0 ms.
- ▶ The "Display monitoring result at the outputs" option must be activated in PAS4000. In this case, the result of the monitoring functions affects the outputs on the module directly if a limit value is violated.
- ▶ At least one monitoring function must be activated for the FS outputs. The monitoring functions are activated by setting the O-data type "...DeactivateSS1M" to FALSE.

4.6 Position counter value

The position counter value is transferred to the head module via the FS module bus and is available in the user program. This function is not available on sensors on which a position cannot be determined (Ini pnp-pnp, pnp-npn, npn-pnp, npn-npn). The valid bit of the position counter value must always be evaluated together with the position counter value.

Reason: In the event of an error or open circuit on the sensor, the valid bit for the position counter value becomes 0, so identifying an invalid position counter value. While the error is present, the position counter value is set to 0.

Please note that movements cannot be recorded during an external error/open circuit. As soon as the valid bit for the position counter value becomes 0, all the reference positions in the user program that have been formed from the position counter value become invalid and must be recalculated when the valid bit returns to 1.

4.7 Integrated protection mechanisms

When the PSSu E F PS1(-T) or PSSu E F PS2(-T)(-R) is used to supply the system, the module supply is buffered for 20 ms if the supply voltage is interrupted.

The module provides the following diagnostic data:

- ▶ Start-up error
- ▶ Configuration error
- ▶ FS communication error
- ▶ Bus termination error
- ▶ Temperature error: too warm
- ▶ Sensor error
- ▶ Output error

The module has the following protection mechanisms:

- ▶ Common second shutdown route, tested regularly
- ▶ Cyclical output tests

4.8 Reaction times

Maximum reaction time from the moment a monitored limit value is violated to the shutdown of outputs O0, O1, O2 is: 10 ms.

Cascading:

With 8 networked modules, the maximum reaction time from the moment a monitored limit value is violated to the shutdown of all networked modules is: 6 ms.

With 2 networked modules, the typical reaction time from the moment a monitored limit value is violated to the shutdown of all networked modules is: 4.5 ms.

4.9 Configuration

The module has the following configuration options

- ▶ In the properties view in PAS4000
- ▶ In the blocks' properties view
- ▶ Via the blocks' I-variables

4.9.1 Access to I/O data

Access to data during operation is via pre-defined I/O data types and the blocks FS_EI_Basic, FS_EI_SSM0, FS_EI_SOSM, FS_EI_SDIM, FS_EI_SSM1_SSRM:

I-data type: FS_I_DI

I/O data name	I/O data element	Meaning
SSM0_Enable	Data: SAFEBOOL	TRUE: configured limit value for the monitoring function SSM0 has not been violated. FALSE: configured limit value for the monitoring function has been exceeded and the monitoring function SSM0 has been activated
SSM1_Enable	Data: SAFEBOOL	TRUE: configured limit value for the monitoring function SSM1 has not been violated. FALSE: configured limit value for the monitoring function has been exceeded and the monitoring function SSM1 has been activated
SOSM_Enable	Data: SAFEBOOL	TRUE: configured limit value for the monitoring function SOSM has not been violated. FALSE: the limit value for the position tolerance has been exceeded and the monitoring function SOSM has been activated
SDIM_PosEnable	Data: SAFEBOOL	TRUE: configured limit value for the monitoring function SDIM_Pos has not been violated. FALSE: the limit value for the speed has been exceeded and the monitoring function SDIM_Pos has been activated

I/O data name	I/O data element	Meaning
SDIM_NegEnable	Data: SAFEBOOL	TRUE: configured limit value for the monitoring function SDIM_Neg has not been violated. FALSE: the limit value for the speed has been exceeded and the monitoring function SDIM_Neg has been activated
SSRM_Enable	Data: SAFEBOOL	TRUE: configured limit values for the monitoring function SSRM has not been violated. FALSE: limit values for the speed has been exceeded and the monitoring function SSRM has been activated

I-data type: FS_I_EI_SPEED

I/O data name	I/O data element	Meaning
Speed	Speed: SAFEWORD	Current speed value in compressed form

I-data type: FS_I_EI_STATE:

I/O data name	I/O data element	Meaning
State	AcknowledgementRequired: BOOL	TRUE: An error has been reported, which must be acknowledged. FALSE: No error detected
State	AutomaticSTO: SAFE- BOOL	TRUE: The value for the option "Automatic STO at standstill" has fallen below the set limit value and standstill has been detected. FALSE: Standstill not detected or SS1 not activated.
State	SensorMissing: BOOL	TRUE: No sensor connected FALSE: Sensor connected
State	StateCascading:BOOL	TRUE: No networked module has switched off FALSE: At least one networked module has switched off
State	StateRestartInhibit: SAFEBOOL	TRUE: corresponds to the "sum" of the local safety functions and the restart interlock inactive FALSE: Restart interlock active
State	StateSTO_Timer1: SAFEBOOL	TRUE: the set STO delay time for output O1 is running. FALSE: the set STO delay time for output O1 has not been started or has already elapsed.
State	StateSTO_Timer2: SAFEBOOL	TRUE: the set STO delay time for output O2 is running. FALSE: the set STO delay time for output O2 has not been started or has already elapsed.

I-data type: FS_I_EI_PARA

I/O data name	I/O data element	Meaning
Parameters	Handshake: SAFEBOOL	Module has adopted new parameter value
Parameters	ParameterError: SAFE- BOOL	TRUE: An incorrect parameter has been transferred FALSE: No error

I-data type: FS_I_EI_CV

I/O data name	I/O data element	Meaning
CounterValue	CurrentData: SAFE- WORD	Position counter value as 32 bit value

O-data type: ST_O_DO

I/O data name	I/O data element	Meaning
O0	Data: BOOL	TRUE: Switch on output 0 FALSE: Switch off output 0

O-data type: FS_O_DO:

I/O data name	I/O data element	Meaning
O1	Data: SAFEBOOL	TRUE: Switch on output 1 FALSE: Switch off output 1
O2	Data: SAFEBOOL	TRUE: Switch on output 2 FALSE: Switch off output 2
SSM0_DeactivateSS1M	Data: SAFEBOOL	TRUE: Deactivate monitoring function SSM0 for the outputs. FALSE: Activate monitoring function SSM0 for the outputs.
SSM1_DeactivateSS1M	Data: SAFEBOOL	TRUE: Deactivate monitoring function SSM1 for the outputs. FALSE: Activate monitoring function SSM1 for the outputs.
SSRM_DeactivateSS1M	Data: SAFEBOOL	TRUE: Deactivate monitoring function SSRM for the outputs. FALSE: Activate monitoring function SSRM for the outputs.
SOSM_DeactivateSS1M	Data: SAFEBOOL	TRUE: Deactivate monitoring function SOSM for the outputs. FALSE: Activate monitoring function SOSM for the outputs.

I/O data name	I/O data element	Meaning
SDIM_PosDeactivateSS1M	Data: SAFEBOOL	TRUE: Deactivate monitoring function SDIM-Pos for the positive direction for the outputs. FALSE: Activate monitoring function SDIM-Pos for the positive direction for the outputs.
SDIM_NegDeactivateSS1M	Data: SAFEBOOL	TRUE: Deactivate monitoring function SDIM-Neg for the negative direction for the outputs. FALSE: Activate monitoring function SDIM-Neg for the negative direction for the outputs.

O-data type: FS_O_EI_CONTROL

I/O data name	I/O data element	Meaning
BasicInterface	ActivateCascading: BOOL	TRUE: Enable cascading output. FALSE: Switch off cascading output.
BasicInterface	Alive: SAFEBOOL	Only used internally
BasicInterface	ErrorAcknowledgement: BOOL	TRUE: Reset error
BasicInterface	Restart: SAFEBOOL	TRUE: Reset restart interlock

O-data type: FS_O_EI_REFPOS

I/O data name	I/O data element	Meaning
SetSDIM	Set: SAFEBOOL	TRUE: Restart of monitoring functions SDIM
SetSDIM	Alive: SAFEBOOL	Only used internally
SetSOSM	Set: SAFEBOOL	TRUE: Restart of monitoring functions SOSM
SetSOSM	Alive: SAFEBOOL	Only used internally

O-data type: FS_O_EI_SSR_PARA

I/O data name	I/O data element	Meaning
SSR_Parameter	Alive: SAFEBOOL	Only used internally
SSR_Parameter	MaxSpeed: SAFEWORD	Maximum speed for Safe Speed Range Monitoring (SSRM) and limit value for Safe Speed Monitoring 1 (SSM1) in compressed form.
SSR_Parameter	MinSpeed: SAFEWORD	Minimum speed for Safe Speed Range Monitoring (SSRM) in compressed form

4.10 Proximity switches

- ▶ The following proximity switches can be used with a pnp or npn output:
 - Inductive
 - Capacitive
- ▶ The proximity switches must be fitted so that at least one is always activated. In other words, the proximity switches must be fitted so that the recorded signals always overlap.
- ▶ The cable used to connect the proximity switches must be shielded (see connection diagrams in the chapter entitled "EMC-compliant wiring").
- ▶ A DC voltage in the range of 0 - 30 V can be monitored via track S. It should be used to monitor the supply voltage of the proximity switches.



CAUTION!

Please note: Connection of the proximity switches may only be performed in three-wire technology and not in two-wire technology.

Proximity switch assembly:

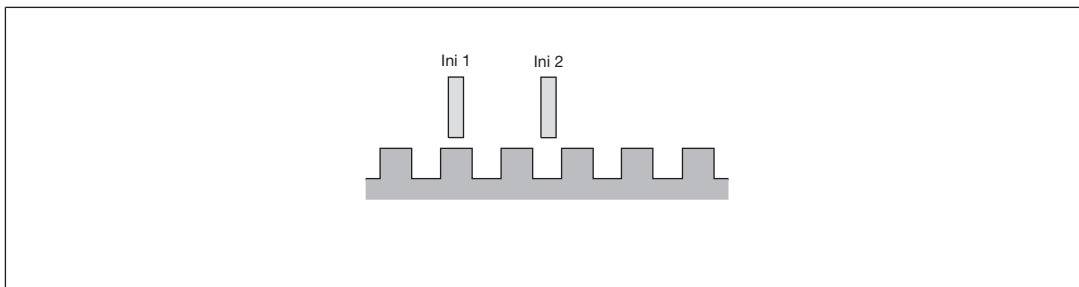

Signal characteristics:

Proximity switch combinations	Signal image during movement
PNP / PNP	
NPN / NPN	

Proximity switch combinations	Signal image during movement
NPN / PNP	<p>De-energise energised energised De-energise</p> <p>Ini 1</p> <p>Ini 2</p> <p>> 1% of period length</p>
PNP / NPN	<p>energised De-energise De-energise energised</p> <p>Ini 1</p> <p>Ini 2</p> <p>> 1% of period length</p>

**CAUTION!**

Appropriate installation measures should be taken to prevent a foreign body coming between the signal encoder and the proximity switch. If not, the foreign body could cause invalid signals.

- ▶ Please note the values stated in the sensor's technical details.
- ▶ For a full configuration, the maximum frequency of the sensors you are using must be entered in PAS4000 (see sensor's data sheet).

4.11**Encoder**

- ▶ The following encoders can be used:
 - TTL, HTL (single-ended or differential signals)
 - Sin/Cos 1 Vss
 - Hiperface®
- ▶ The encoders can be connected with or without Z index (0 index).
- ▶ The cables used to connect the encoders must be shielded (see connection diagrams in the chapter entitled "EMC-compliant wiring").
- ▶ A pnp proximity switch can also be connected to track Z for monitoring broken shear-pins.

Please note:

Monitoring for broken shearpins does not become active until

- The minimum speed has been exceeded and

- The tolerance for detecting feasibility errors has elapsed.

The minimum speed and tolerance depend on the ratio of the frequency at tracks AB " f_{AB} " to the frequency at track Z " f_Z " in your configuration.

Minimum speed:

- Calculated ratio $AB/Z \geq 1.0$
 $f_Z = 10 \text{ mHz}$ or $f_{AB} = (f_{AB}/f_Z) \times 10 \text{ mHz}$
- when $f_{AB}/f_Z \text{ Verh.} < 1.0$
 $f_{AB} = 10 \text{ mHz}$ or $f_Z = 10 \text{ mHz}/(f_{AB}/f_Z)$

Tolerance for detecting feasibility errors:

- when $f_{AB}/f_Z \text{ Verh.} \geq 1.0$
 7.5 Z-pulses or $7.5 \times (f_{AB}/f_Z) \text{ AB-pulses}$
- when $f_{AB}/f_Z \text{ Verh.} < 1.0$
 4.5 AB-pulses or $4.5/(f_{AB}/f_Z) \text{ Z-pulses}$
- ▶ With Hiperface encoders, only the RefSin and RefCos tracks are recorded and monitored (see [Adapters for encoders](#) [37]).
- ▶ Track S can be used:
 - To connect an encoder's error output.
 - To monitor voltages between 0 V and 30 V for a permitted upper and lower limit. For example, the encoder's supply voltage can be monitored.
- ▶ The maximum frequency of the used encoders must be entered for a complete configuration.
- ▶ Pay attention to the values in the technical details.

4.11.1 Output signals

Output signals TTL, HTL

Single ended

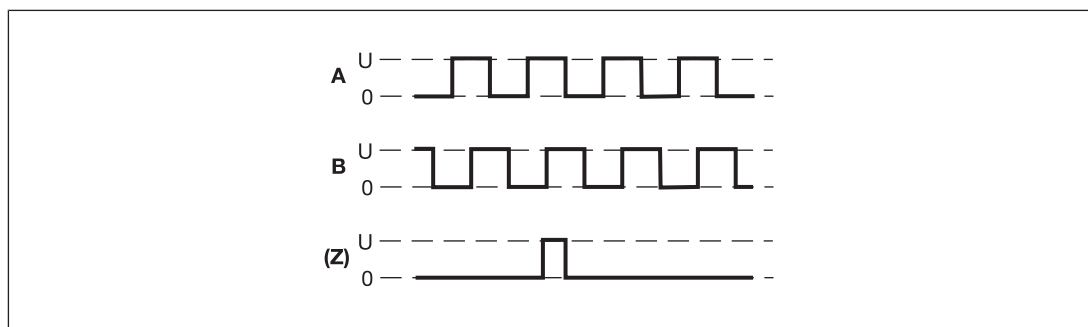

Differential

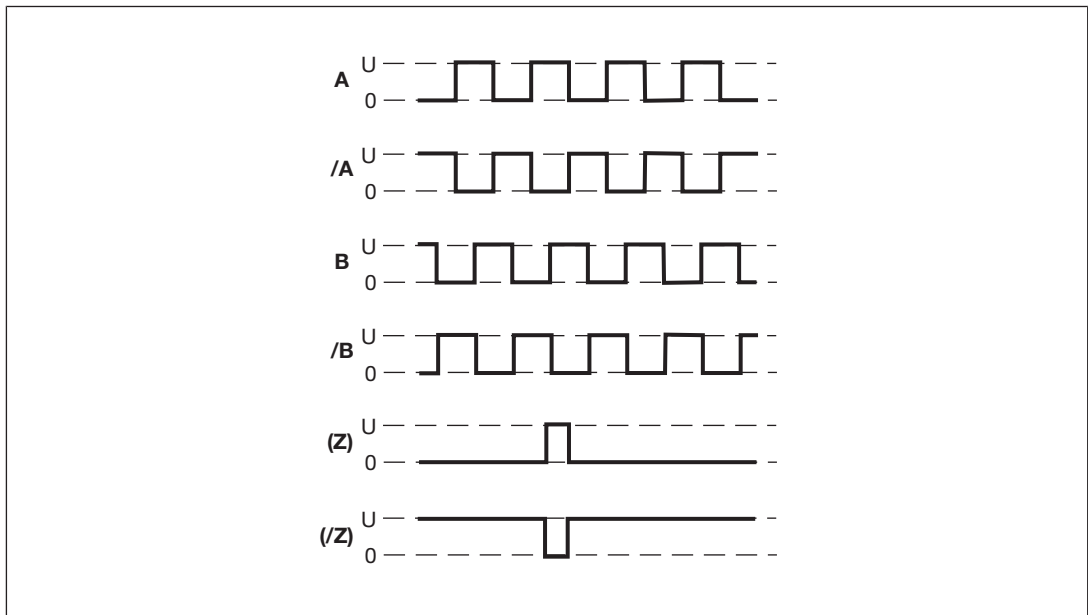

Output signals Sin/Cos (1 Vss)

Single ended with reference track (e.g. Hiperface ®)

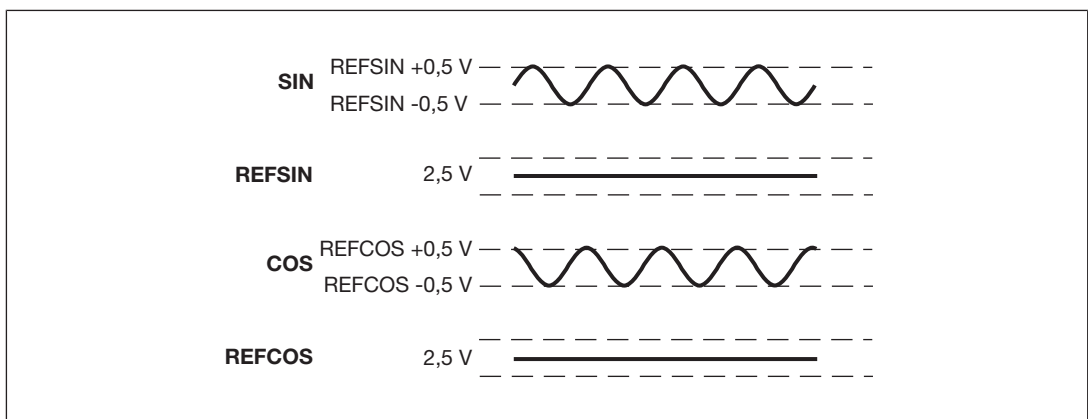

Differential with/without Z index (e.g. Heidenhain 1 Vss)

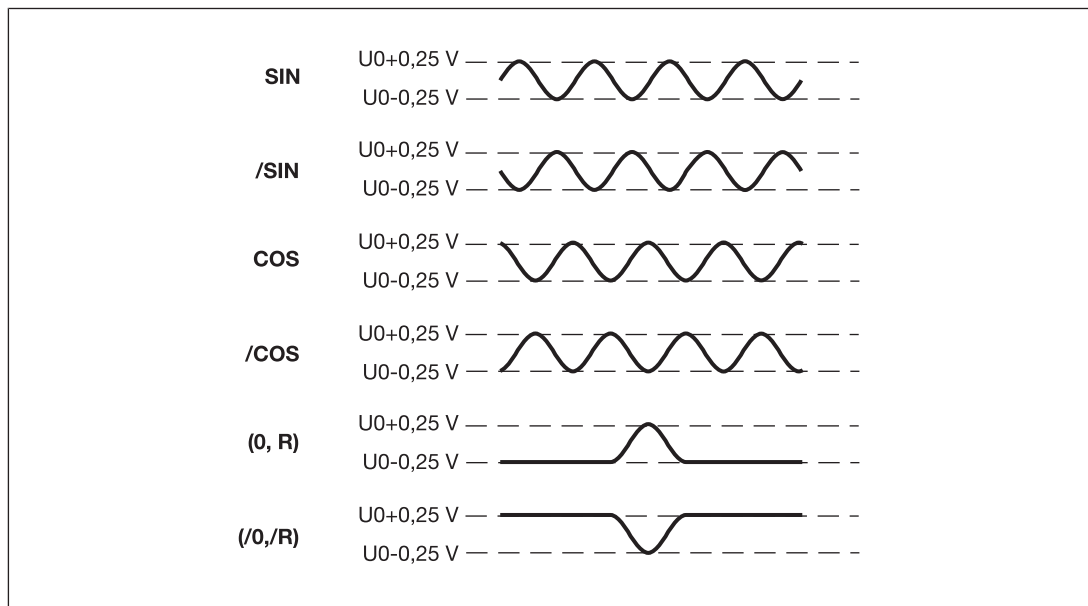

- ▶ Tracks Z and /Z can also be inverted
- ▶ With a SinCos encoder, the voltage U_0 is 2.5 V

4.11.2 Adapters for encoders

The adapter records the data between the encoder and the drive and makes it available to the module via the Mini-IO socket.

Pilz supplies complete adapters as well as ready-made cable with Mini-IO connector, which can be used when making your own adapter. The range of products in this area is constantly being expanded. Please contact us about the range of adapters that is currently available.

5 Installation

5.1 General installation guidelines

Please refer also to the PSSuniversal Installation Manual.



NOTICE

Damage due to electrostatic discharge!

Electrostatic discharge can damage components. Ensure against discharge before touching the product, e.g. by touching an earthed, conductive surface or by wearing an earthed armband.

5.1.1 Dimensions

Module with connector:

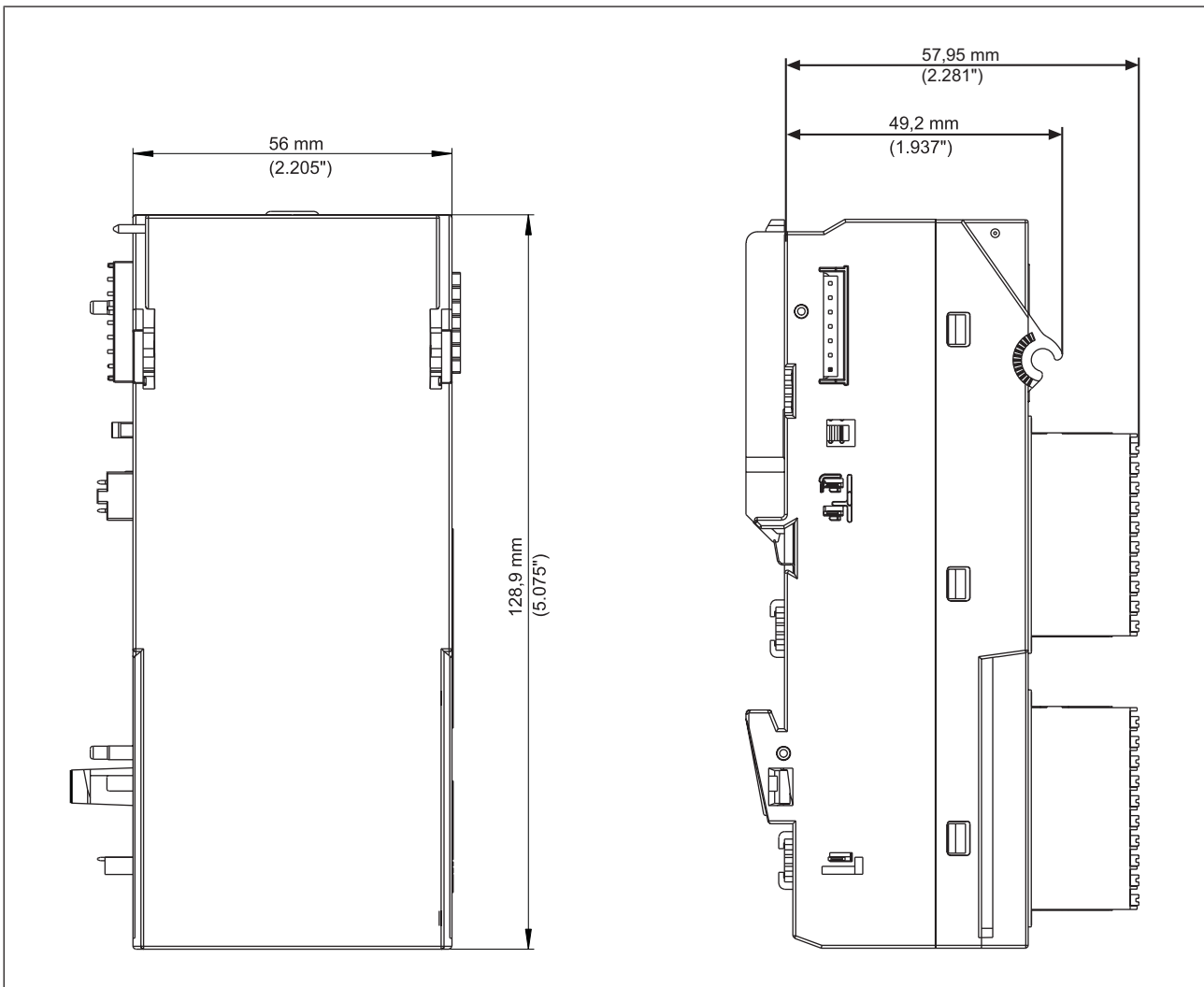

Module with connector and labelling bracket:

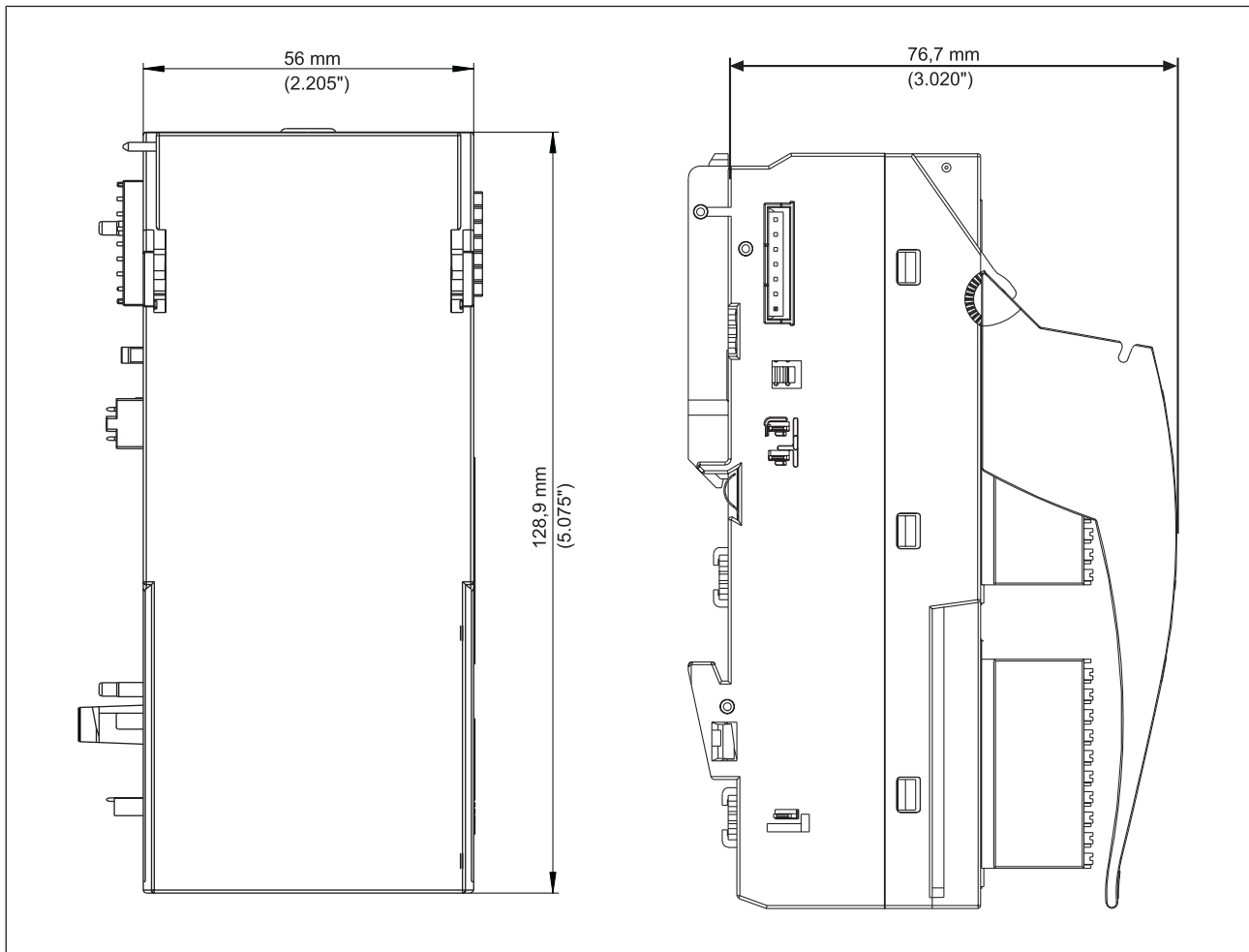

5.2 Install compact module

Prerequisite:

- ▶ The head module must be installed.
- ▶ If the head module does not have an integrated power supply, a supply voltage module must be installed to the right of the head module.
- ▶ A base module with screw terminals may not be installed to the left of the compact module.

Please note:

- ▶ All contacts should be protected from contamination.
- ▶ The mechanics of the compact modules are designed for 50 plug in/out cycles.

Procedure:

- ▶ Slot the groove on the compact module on to the mounting rail from below [1].
- ▶ Push the compact module back as far as it will go [2].
- ▶ Make sure that the locking mechanism [3] is pushed downwards, connecting the module firmly to the mounting rail.
- ▶ On the mounting rail, slide the compact module to the left.

**NOTICE****Potential contact damage due to twisting!**

The contacts for the Module Supply and Periphery Supply can be bent by twisting the compact modules on the mounting rail.

- On the mounting rail, carefully slide the compact module to the left, in parallel to the adjoining module, until you hear the lateral mounting hooks on the adjacent module lock into position [4].

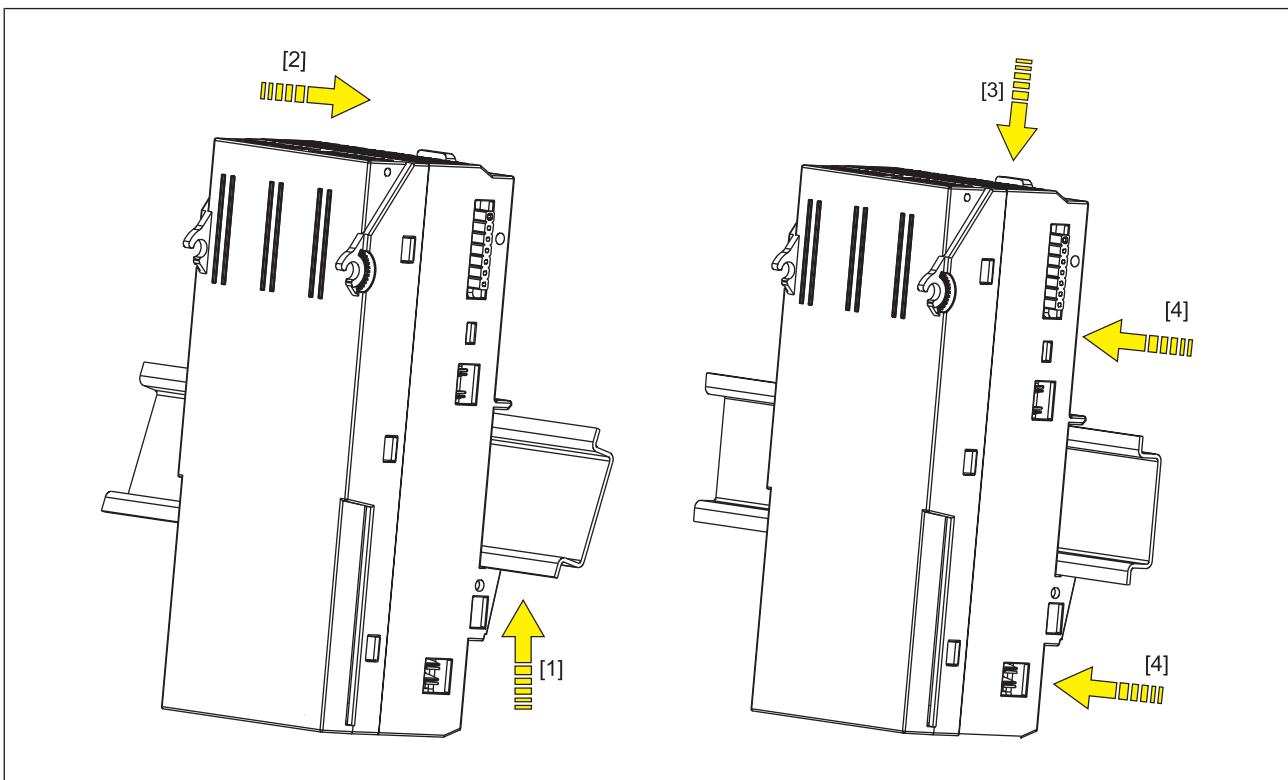

Fig.: Install compact module

5.3 Install/uninstall connector

We recommend that the connectors with spring-loaded terminals are wired before they are plugged in.

Please note:

- ▶ All contacts should be protected from contamination.
- ▶ The mechanics of the connector are designed for 25 plug in/out cycles.

Installation procedure:

- ▶ Plug the connector into the required connector strip until it locks into position.

Uninstallation procedure:

- ▶ Pull the connector on the connector housing upwards.

**NOTICE**

As you remove the connector, grasp the connector housing and not the cable harness.

5.4 Install labelling bracket

Installation procedure:

- ▶ We recommend that the labelling strips are attached to the labelling bracket prior to installation.
- ▶ Slot the two pins on the labelling bracket into the receiving lugs on the module [1].
- ▶ Check that the labelling bracket is firmly seated.

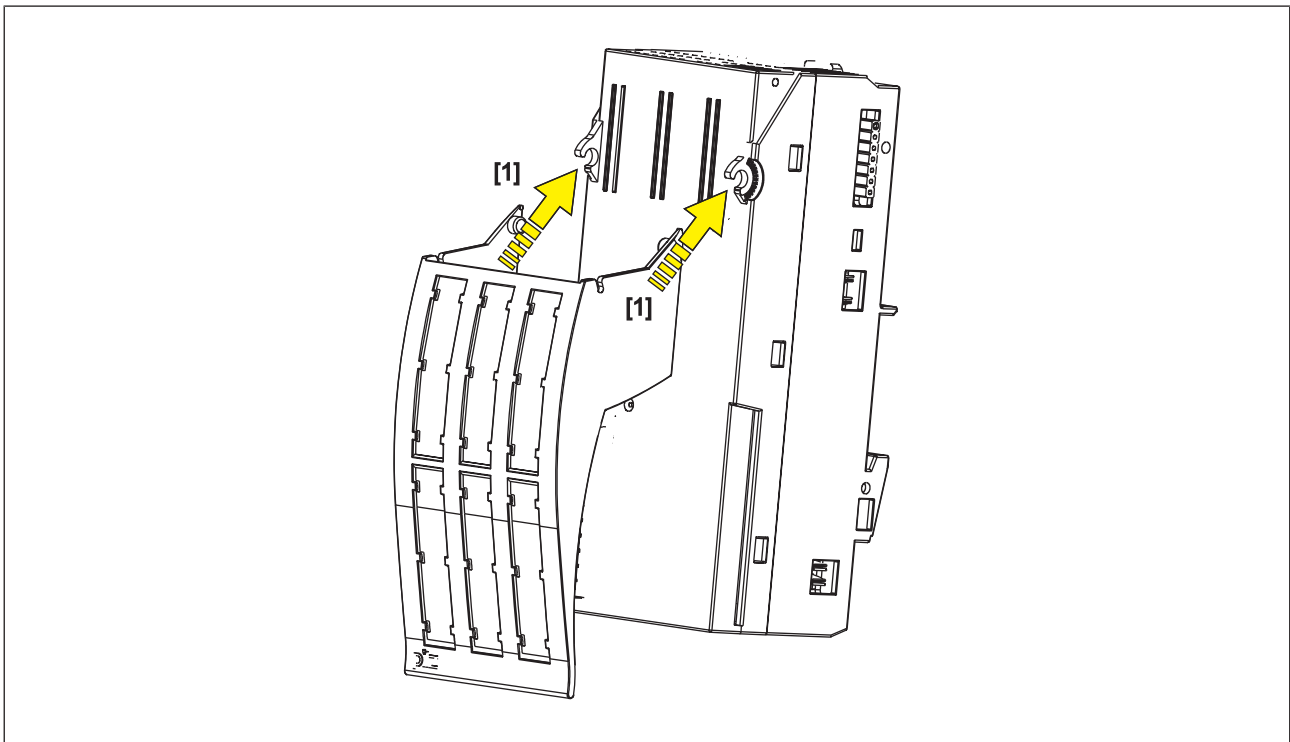

Fig.: Install labelling bracket

6 Wiring

6.1 Connectors' mechanical connection

Please note:

- ▶ The conductor cross section on the spring-loaded terminals without ferrules is 0,2 - 1 mm², 22 - 18 AWG.
- ▶ If you are using multi-core or fine-core cables we recommend ferrules in accordance with DIN 46228/Part 1 or DIN 46228/Part 4, 0.2 ... 1 mm². To crimp the ferrules we recommend crimping pliers (crimp form A) conforming to EN 60947-1, such as the PZ 6/5 from Weidmüller, for example.
- ▶ Terminal points per connection: 1
- ▶ Stripping length: 8 mm

6.2 Connect/disconnect the cables

We recommend you use a screw driver with a 0.4 x 2.5 mm (DIN 5264) blade!

Strip the cable:

- ▶ Strip the cable [1] and apply a ferrule if necessary (DIN 46228/Part 1 or DIN 46228/Part 4).

Connect cable:

- ▶ Using the screwdriver, press the actuator button on the spring-loaded terminal down as far as it will go [2], keep it held down and insert the stripped cable into the plug connection as far as it will go [2].
- ▶ Check that the cable is firmly seated [3].

Disconnect cable:

- ▶ Using the screwdriver, press the actuator button down as far as it will go [4], keep it held down and pull the cable out of the plug connection [4].

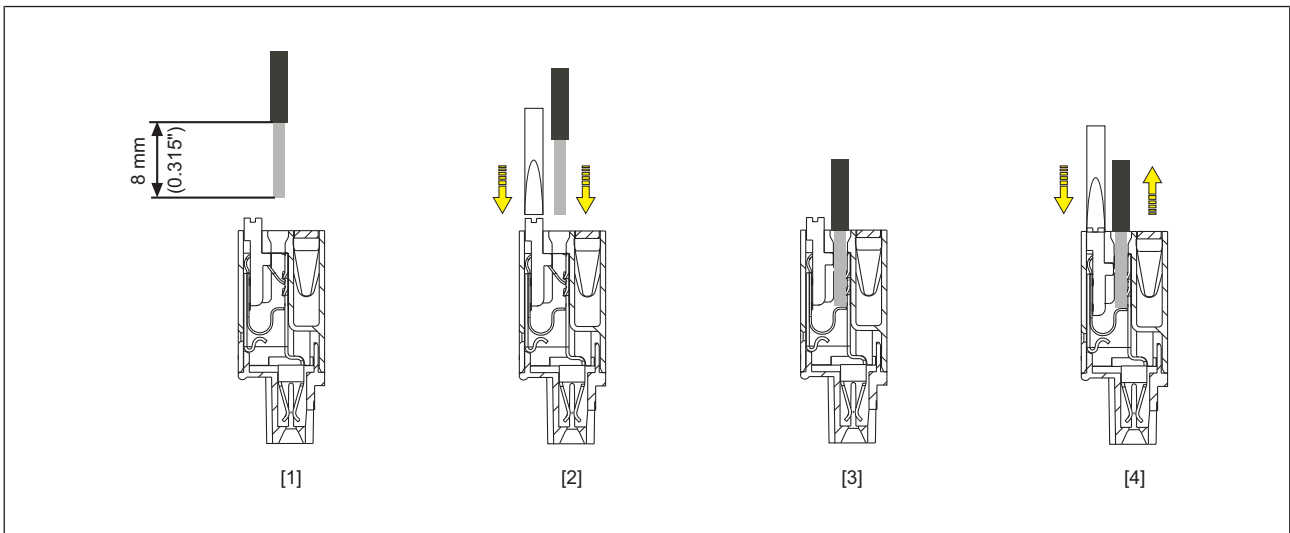

Fig.: Connect and disconnect the cables

6.3 Supply voltage

Terminal configuration (1-row): PSSu A Con 1/10 C	
<p>X13:</p> <p>24 V>: +24 V (external periphery supply)</p> <p>O 0: Single-pole ST output</p> <p>O 1: Single-pole FS output</p> <p>O 2: Single-pole FS output</p> <p>NC</p> <p>NC</p> <p>NC</p> <p>NC</p> <p>CIO-: Input/output for networking additional modules</p> <p>0 V>: 0 V (external periphery supply)</p>	<p>24 V</p> <p>10 A</p> <p>X13</p> <p>24 V></p> <p>O 0</p> <p>O 1</p> <p>O 2</p> <p>n.c.</p> <p>n.c.</p> <p>n.c.</p> <p>n.c.</p> <p>CIO-</p> <p>0V></p> <p>10</p> <p>0 V</p>

6.4 Connection of proximity switches

Terminal configuration (1-row): PSSu A Con 1/5 C	
X32: Ini A Ini B Ini Z Ini S 0 V	

The following proximity switch combinations can be connected:

- ▶ A: pnp, B: pnp
- ▶ A: npn, B: npn
- ▶ A: pnp, B: npn
- ▶ A: npn, B: pnp

When connecting proximity switches please note:

- ▶ Proximity switches can be connected to
 - terminals Ini A, Ini B, 0 V
 - or
 - tracks A, B and 0 V of the Mini-IO socket.
- ▶ Track S should be used to monitor the supply voltage (see drawing). A permitted voltage range can be entered in the PAS4000.
- ▶ Connect the proximity switch to 24 VDC of the power supply.
- ▶ When connecting the proximity switches, please refer to the chapter entitled "EMC-compliant wiring".
- ▶ Invalid signals may occur with cable lengths >50 m. In this case we recommend that you connect a resistor between the signal lines, as shown in the diagrams.

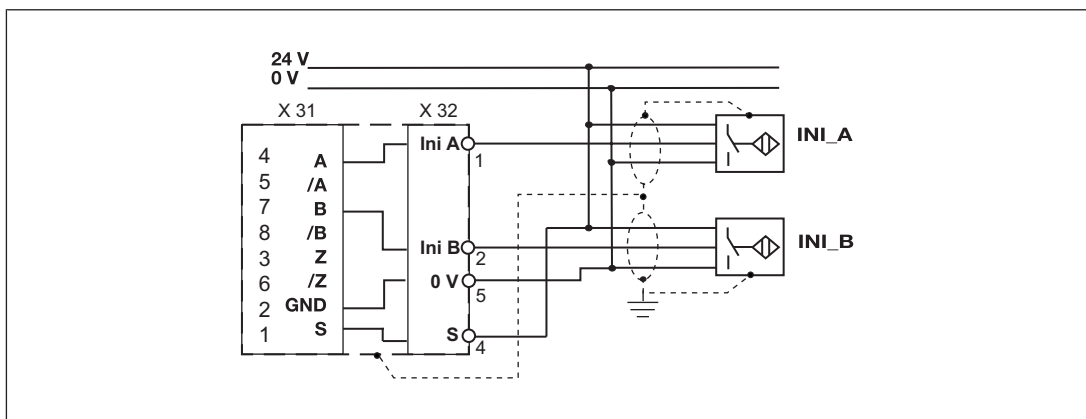

pnp proximity switch with resistor R = 10 kOhm

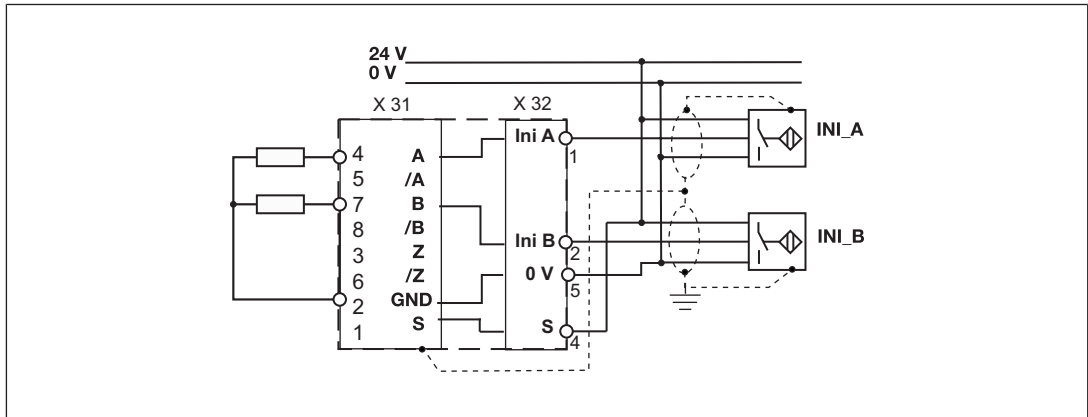

npn proximity switch with resistor R = 47 kOhm

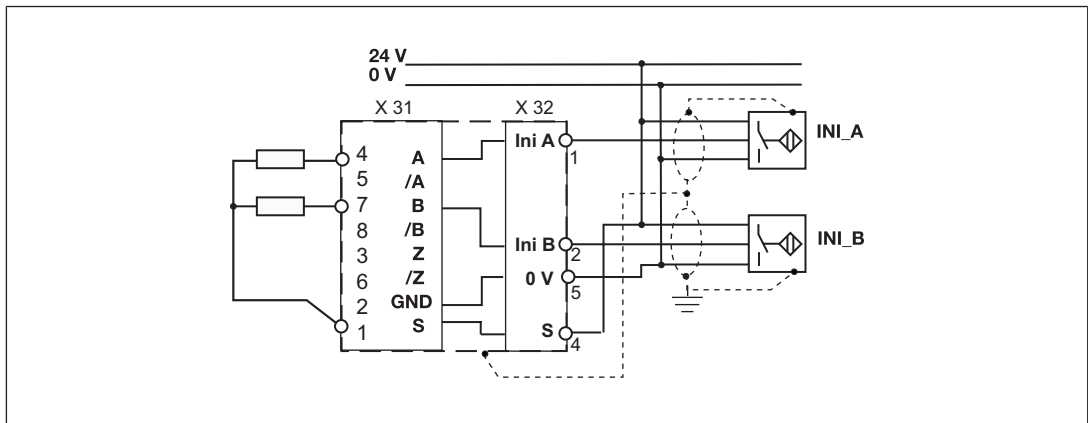

6.5 Connection of encoders

Connector pin assignment X31, depending on the technology

Mini-IO socket				
8-pin	PIN	HTL/TTL	Sin/Cos	Hiperface
	1	S (optional)	S (optional)	S (optional)
	2	GND	GND	GND
	3	Z	Z or index	
	4	A	Sin	Sin
	5	/A	-Sin	RefSin
	6	/Z	Z or index	
	7	B	Cos	Cos
	8	/B	-Cos	RefCos

Proceed as follows when connecting the encoder:

- ▶ Use only shielded cables for all connections. Please refer to the chapter [EMC-compliant wiring](#) [51].
- ▶ Always connect GND on the encoder to GND on the Mini-IO socket.

6.5.1 Connect encoder

Encoder types:

- ▶ TTL single ended
- ▶ HTL single ended

Please note:

- ▶ Tracks /A, /B, Z, and /Z must remain free

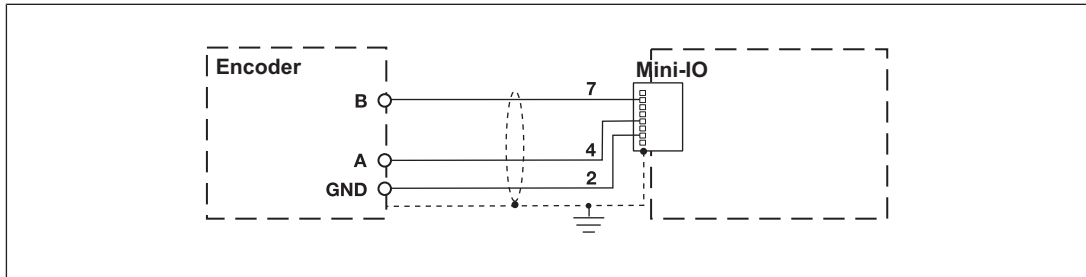

Encoder types:

- ▶ TTL differential
- ▶ HTL differential
- ▶ sin/cos 1 Vss
- ▶ Hiperface

Please note:

- ▶ Tracks Z and /Z must remain free

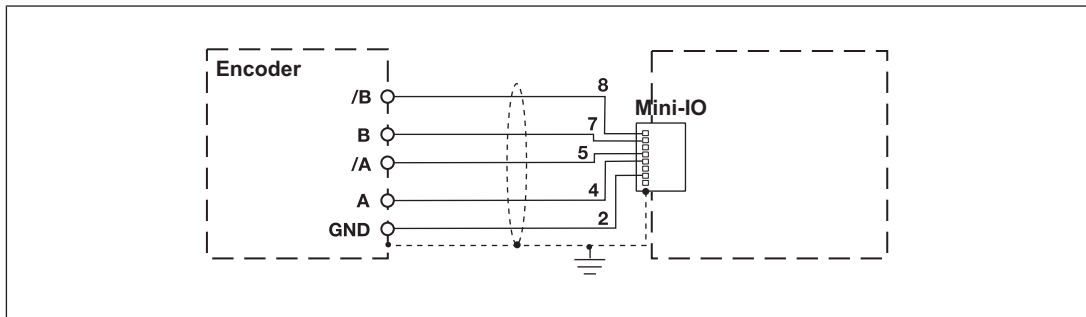

6.5.2 Connect encoder with Z index

Encoder types:

- ▶ TTL single Z Index
- ▶ HTL single Z Index

Please note:

- ▶ Tracks /A, /B and /Z must remain free

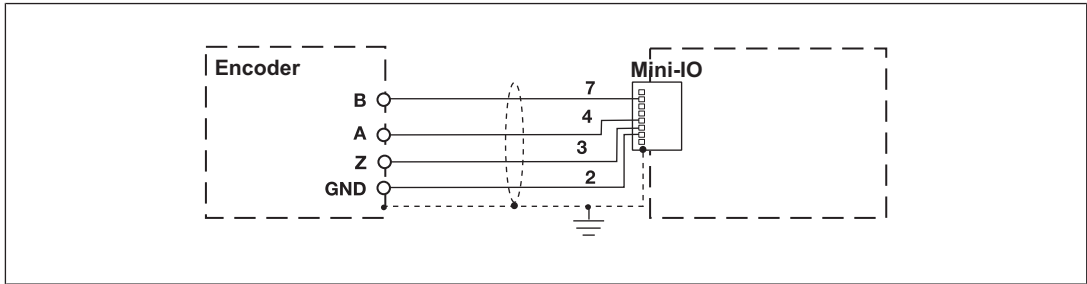

Encoder types:

- ▶ TTL diff. Z Index
- ▶ HTL diff. Z Index
- ▶ sin/cos 1 Vss Z Index

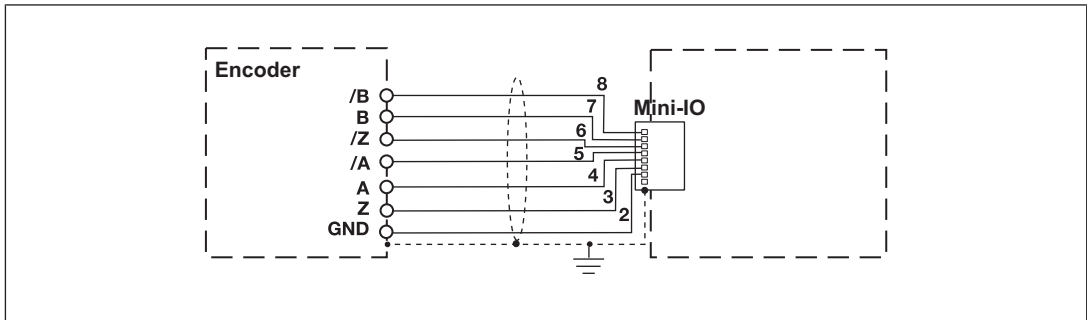

6.5.3 Connect encoder via an adapter

The adapter (e.g. PNOZ msi6p) is connected between the encoder and the drive. The output on the adapter is connected to the Mini-IO socket on the module.

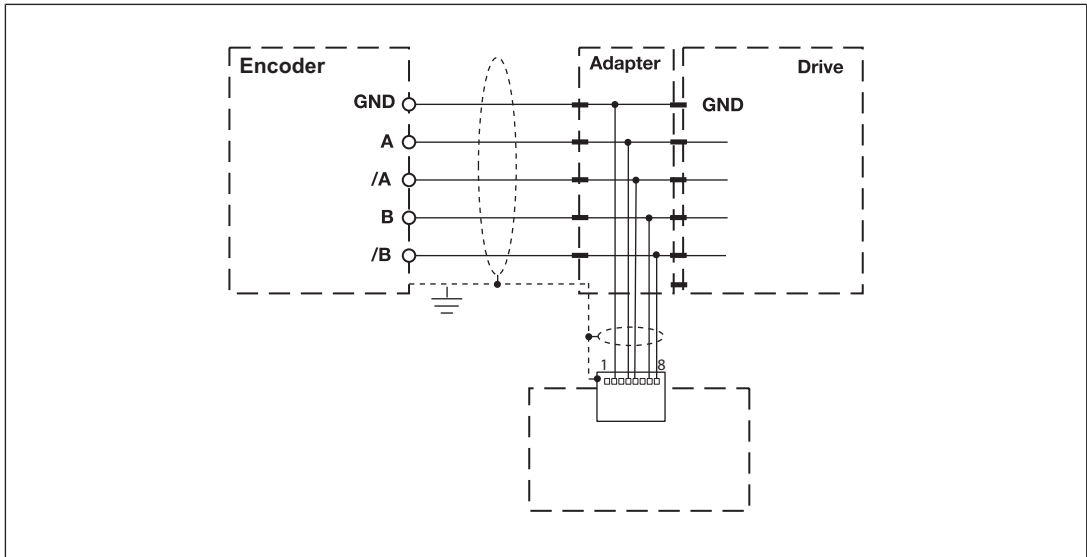

6.6 Connection of proximity switch and encoder

When connecting the encoders and proximity switches, please refer to the chapter entitled "EMC-compliant wiring".

Sensor types:

- ▶ Configuration: HTL single Z Freq. Ini pnp
 - HTL single ended (A,B) + Ini pnp (Z)
 - HTL single ended (A,B) + HTL differential (A as Z)
 - HTL single ended (A,B) + HTL single ended (A as Z)
- ▶ Configuration: TTL single Z Freq. Ini pnp
 - TTL single ended (A,B) + Ini pnp (Z)
 - TTL single ended (A,B) + HTL differential (A as Z)
 - TTL single ended (A,B) + HTL single ended (A as Z)

Please note:

Tracks /A, /B and /Z must remain free.

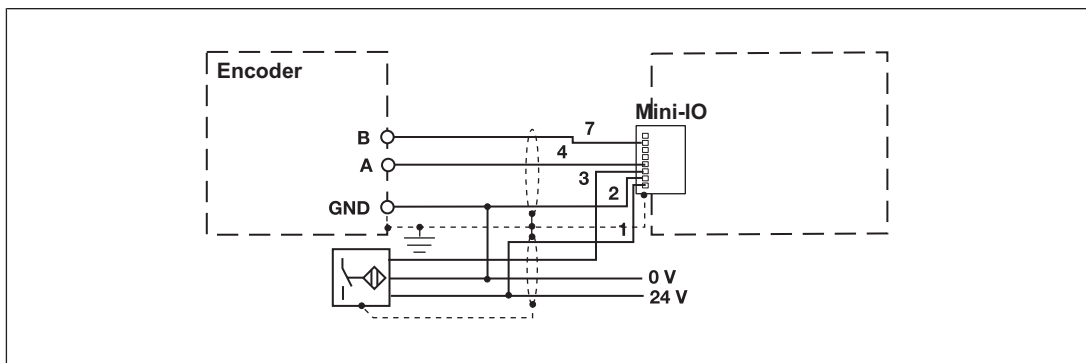

Sensor types:

- ▶ Configuration: TTL differential Z Freq. Ini pnp
 - TTL differential (A,/A,B,/B) + Ini pnp (Z)
 - TTL differential (A,/A,B,/B) + HTL differential (A as Z)
 - TTL differential (A,/A,B,/B) + HTL single ended (A as Z)
- ▶ Configuration: HTL differential Z Freq. Ini pnp
 - HTL differential (A,/A,B,/B) + Ini pnp (Z)
 - HTL differential (A,/A,B,/B) + HTL differential (A as Z)
 - HTL differential (A,/A,B,/B) + HTL single ended (A as Z)
- ▶ Configuration: sin/cos 1 Vss Z Freq. Ini pnp
 - sin/cos 1 Vss (A,/A,B,/B) + Ini pnp (Z)
 - sin/cos 1 Vss (A,/A,B,/B) + HTL differential (A as Z)
 - sin/cos 1 Vss (A,/A,B,/B) + HTL single ended (A as Z)
- ▶ Configuration: Hiperface Z Freq. Ini pnp
 - Hiperface (A,/A,B,/B) + Ini pnp (Z)
 - Hiperface (A,/A,B,/B) + HTL differential (A as Z)

- Hiperface (A,/A,B,/B) + HTL single ended (A as Z)

Please note:

Track /Z must remain free

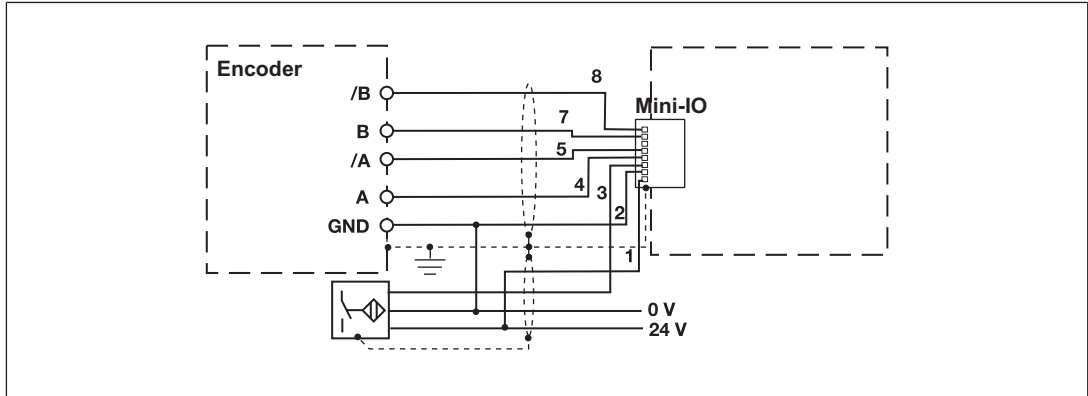

6.7 EMC-compliant wiring

EMC-compliant wiring for connecting an encoder

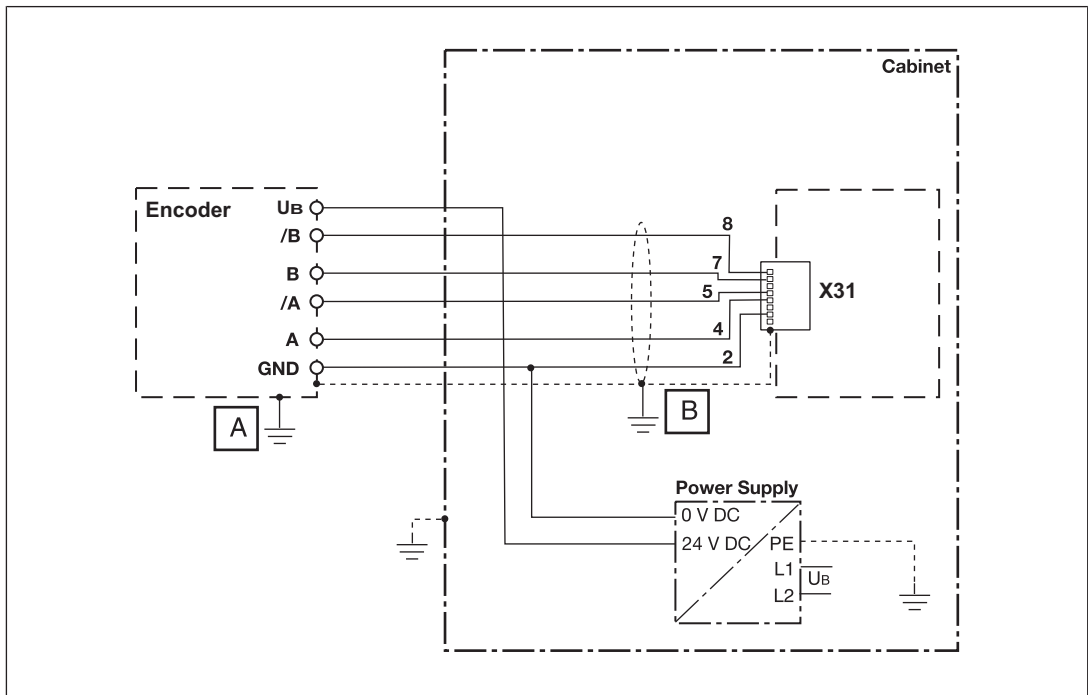

To avoid EMC interference we recommend that the shield on the sensor lines is only connected to earth at a single point:

A or B

Conductor loops outside the shield must be avoided.

The shield must run continuously from the sensor to the evaluation device.

EMC-compliant wiring for connecting an encoder with drive

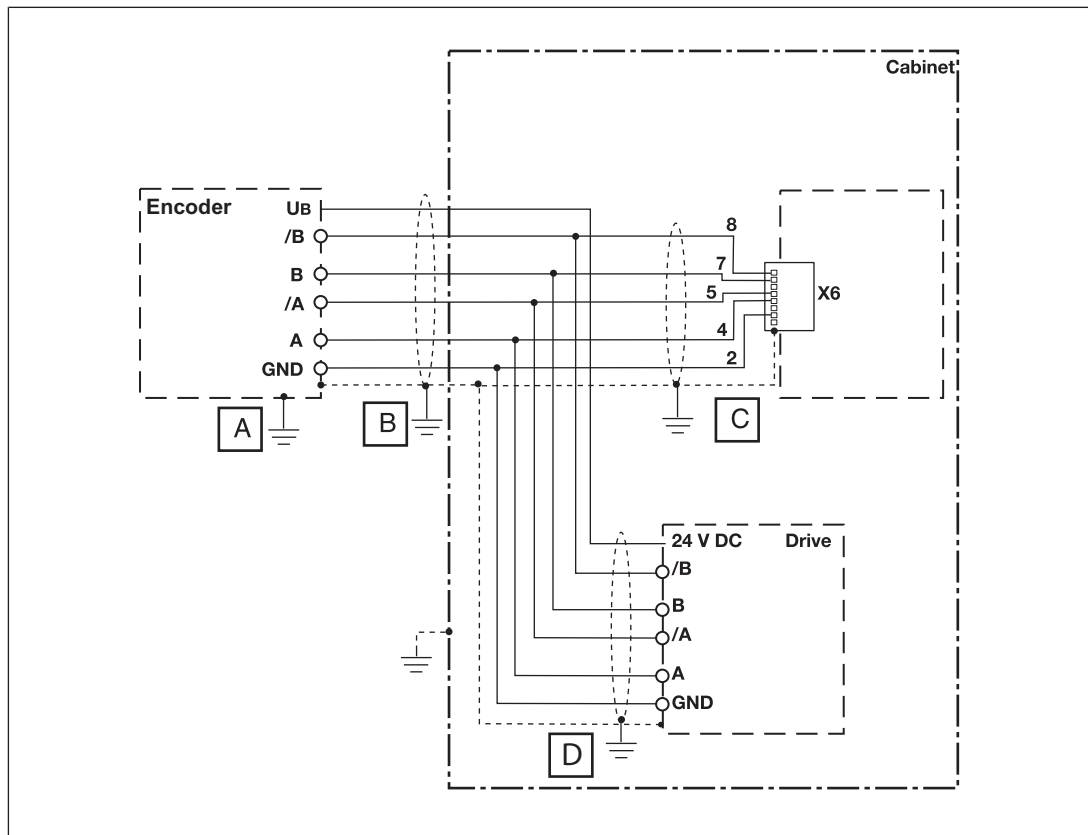

To avoid EMC interference we recommend that the shield on the sensor lines is only connected to earth at a single point:

A or B or C or D

Conductor loops outside the shield must be avoided.

The shield must run continuously from the sensor to the evaluation device.

EMC-compliant wiring for connecting 2 proximity switches

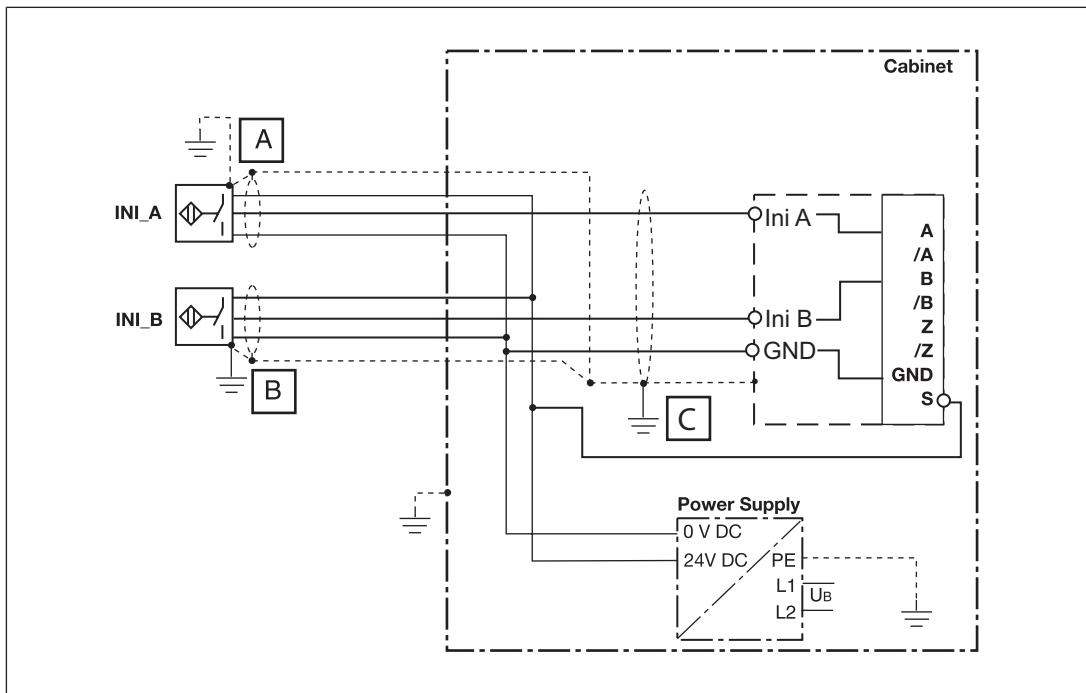

To avoid EMC interference we recommend that the shield on the sensor lines is only connected to earth at a single point:

A or B or C

Conductor loops outside the shield must be avoided.

The shield must run continuously from the sensor to the evaluation device.

6.8 Function test during commissioning

An error must be simulated for each safety-related output during commissioning: The anticipated error reaction must occur when an output has a short circuit to a supply voltage.



INFORMATION

The short circuit test must be performed on the load and not on the output terminal.

7 Operation

7.1 Messages



A module error is displayed via the "Err" LED, signalled to the head module and then entered in the head module's diagnostic log.

The module can detect the following errors:

Module error	Statement	Remedy
Start-up error	Error as the PSSu system starts up	Change faulty module.
Configuration error	Incorrect module type configured.	The configured hardware registry does not match the actual hardware registry.
FS communication error	Error during FS communication	Change faulty module.
Bus termination error	There is no terminating plate or there is a bad contact with the module bus.	Install a terminating plate with integrated end bracket or insert the base modules together correctly.
Temperature error: too warm	Ambient temperature too high: Error stack entry/diagnostic log entry	Ensure there is sufficient ventilation in the control cabinet or prevent overload.
Output error	Error during cyclical output test for short circuit. Possible causes: Short circuit, or output defective.	Rectify the short circuit or change the faulty module.
Encoder error	No encoder connected	The encoder must be connected correctly
Parameter error	Incorrect parameter (Max_Speed or Min_Speed)	Change the parameter





7.2 Display elements

Legend

-  LED on
-  LED flashes
-  LED off

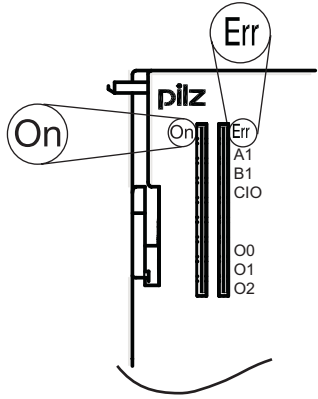
7.2.1 Display elements for module diagnostics

The module has an LED for displaying operating states ("On" LED) and module errors ("Err" LED).

	LED			Meaning
	Designation	Colour	Status	
On	---		●	Module is not in operation
	Green			Module in operation
Err	---		●	No fault
	Red			External error (open circuit, short circuit, incorrect sensor configuration)
				Module is faulty

7.2.2 Display elements for input and output status

Each input and output is assigned an LED to display the status

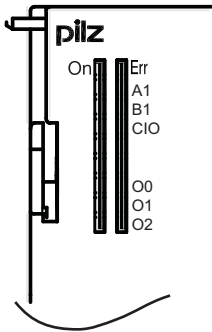
	LED			Meaning	
	Designation	Colour	Status	Signal	Description
A1	---		●	0 signal	Frequency < 10 Hz:
	Green		☀	1 signal	Signal state of sensor track A (/A or Sin or Ini A)
			●☀		Frequency ≥ 10 Hz
B1	---		●	0 signal	Frequency < 10 Hz:
	Green		☀	1 signal	Signal state of sensor track B (/B or Cos or Ini B)
			●☀		Frequency ≥ 10 Hz
CIO	---		●	0 signal	Cascading inactive
	Green		●☀	1 signal	Module has triggered the shutdown
			☀	1 signal	A networked module has triggered the shutdown
O0	---		●	0 signal	ST output
	Green		☀	1 signal	
O1	---		●	0 signal	Single-pole FS output
O2	Green		☀	1 signal	O 1 O 2

8 Technical details

General	312434	314434
Approvals	CE, TÜV, cULus Listed	CE, TÜV
Application range	Failsafe	Failsafe
Module's device code	0F24h	0F24h
Number of FS output bits	2	2
Number of FS status bits	2	2
Number of FS control bits	2	2
Application in system environment		
B		
From FS firmware version, head modules	1.15.0	1.16.0
Electrical data	312434	314434
Supply voltage		
for	Module supply	Module supply
Voltage	5 V	5 V
Kind	DC	DC
Voltage tolerance	-4 %/+4 %	-4 %/+4 %
Output of external power supply (DC)	1,1 W	1,1 W
Supply voltage		
for	Periphery supply	Periphery supply
Voltage	24 V	24 V
Kind	DC	DC
Voltage tolerance	-30 %/+25 %	-30 %/+25 %
Output of external power supply (DC)	1,1 W	1,1 W
Supply voltage		
for	Outputs	Outputs
Voltage	24 V	24 V
Kind	DC	DC
Voltage tolerance	-30 %/+25 %	-30 %/+25 %
Internal supply voltage (module supply)		
Module's power consumption	1,3 W	1,3 W
Periphery's supply voltage (periphery supply)		
Voltage range	16,8 - 30 V	16,8 - 30 V
Module's current consumption with no load	45 mA	45 mA
Module's power consumption with no load	1,35 W	1,35 W
Max. power dissipation of module	3,5 W	3,5 W
Proximity switch input	312434	314434
Number of inputs	2	2

Proximity switch input	312434	314434
Input signal level		
Signal level at "1"	11 - 30 V	11 - 30 V
Signal level at "0"	0 - 3 V	0 - 3 V
Input resistance	22 kOhm	22 kOhm
Input's frequency range	0 - 5 kHz	0 - 5 kHz
Configurable monitoring frequency		
Without hysteresis	0,1 Hz - 5 kHz	0,1 Hz - 5 kHz
Incremental encoder input	312434	314434
Number of inputs	1	1
Connection type	Mini-IO female connector, 8-pin	Mini-IO female connector, 8-pin
Input signal level	0,5 - 30 Vss	0,5 - 30 Vss
Max. number of bits on the counter input	32 Bit	32 Bit
Evaluation of counter pulses	1x, 4x	1x, 4x
Phase position for the differential signals A, /A and B,/B	90° ±30°	90° ±30°
Overload protection	-50 - 65 V	-50 - 65 V
Input resistance	20 kOhm	20 kOhm
Input's frequency range	0 - 500 kHz	0 - 500 kHz
Configurable monitoring frequency		
Without hysteresis	0,1 Hz - 500 kHz	0,1 Hz - 500 kHz
Semiconductor outputs	312434	314434
Number of positive-switching single-pole semiconductor outputs	3	3
Voltage	24 V	24 V
Typ. output current at "1" signal and rated voltage of semiconductor output	0,5 A	0,5 A
Permitted current range	0,000 - 0,620 A	0,000 - 0,620 A
Residual current at "0" signal	0,02 A	0,02 A
Max. transient pulsed current	6 A	6 A
Max. internal voltage drop	100 mV	100 mV
Monitoring threshold of semiconductor output	9 V	9 V
Max. duration of on time during self test	200 µs	200 µs
Max. duration of off time during self test	200 µs	200 µs
Max. processing time of semiconductor output when signal changes from "1" to "0"	0,25 ms	0,25 ms
Max. processing time of semiconductor output when signal changes from "0" to "1"	0,45 ms	0,45 ms
Potential isolation from system voltage	yes	yes

Semiconductor outputs	312434	314434
Potential isolation between semiconductor output and input	yes	yes
Short circuit-proof	yes	yes
Permitted loads	inductive, capacitive, resistive	inductive, capacitive, resistive
Times	312434	314434
Reaction time after limit value is exceeded	1/f_ist + 10ms	1/f_ist + 10ms
Environmental data	312434	314434
Climatic suitability	EN 60068-2-1, EN 60068-2-14, EN 60068-2-2, EN 60068-2-30, EN 60068-2-78	EN 60068-2-1, EN 60068-2-14, EN 60068-2-2, EN 60068-2-30, EN 60068-2-78
Ambient temperature		
In accordance with the standard	EN 60068-2-14	EN 60068-2-14
Temperature range	0 - 60 °C	-40 - 70 °C
Storage temperature		
In accordance with the standard	EN 60068-2-1/-2	EN 60068-2-1/-2
Temperature range	-40 - 70 °C	-40 - 70 °C
Climatic suitability		
In accordance with the standard	EN 60068-2-78	EN 60068-2-78
Humidity	93 % r. h. at 40 °C	93 % r. h. at 40 °C
Condensation during operation	Not permitted	ISO 16750-4
Max. operating height above sea level	2000 m	5000 m
EMC	EN 61131-2	EN 61131-2
Vibration		
In accordance with the standard	EN 60068-2-6	EN 60068-2-6
Frequency	8,4 - 150 Hz	8,4 - 150 Hz
Acceleration	10 m/s²	10 m/s²
Shock stress		
In accordance with the standard	EN 60068-2-27	EN 60068-2-27
Acceleration	15g	15g
Duration	11 ms	11 ms
Airgap creepage		
In accordance with the standard	EN 60664-1	EN 60664-1
Overvoltage category	II	II
Pollution degree	2	2
Protection type		
In accordance with the standard	EN 60529	EN 60529
Housing	IP20	IP20
Mounting area (e.g. control cabinet)	IP54	IP54
Mechanical data	312434	314434
Material		
Bottom	PC	PC
Front	PC	PC
Connection type	Connector strip	Connector strip

Mechanical data	312434	314434
Mounting type	plug-in	plug-in
Conductor cross section with spring-loaded terminals: Flexible with/without crimp connector	0,2 - 1 mm², 22 - 18 AWG	0,2 - 1 mm², 22 - 18 AWG
Spring-loaded terminals: Terminal points per connection	1	1
Stripping length with spring-loaded terminals	8 mm	8 mm
Dimensions		
Height	128,9 mm	128,9 mm
Width	56 mm	56 mm
Depth	56 mm	56 mm
Weight	145 g	145 g

Where standards are undated, the 2016-07 latest editions shall apply.

8.1 Safety characteristic data



NOTICE

You must comply with the safety-related characteristic data in order to achieve the required safety level for your plant/machine.

Unit	Operating mode	EN ISO 13849-1: 2015 PL	EN ISO 13849-1: 2015 Category	EN 62061 SIL CL	EN 62061 PFH_D [1/h]	EN ISO 13849-1: 2015 T_M [year]
Logic						
Input interface	Monitoring 1 encoder	PL d	Cat. 2	SIL CL 2	1,80E-08	20
Input interface	Monitoring 2 encoder	PL e	Cat. 3	SIL CL 3	1,01E-09	20
Input interface	Monitoring safe encoder	PL e	Cat. 4	SIL CL 3	2,35E-09	20
Logic	2-channel	PL e	Cat. 4	SIL CL 3	1,36E-10	20
Output						
SC outputs (1-pole)	1-channel	PL d	Cat. 2	SIL CL 2	3,95E-09	20
SC outputs (1-pole)	2-channel	PL e	Cat. 4	SIL CL 3	8,17E-11	20

All the units used within a safety function must be considered when calculating the safety characteristic data.

**INFORMATION**

A safety function's SIL/PL values are **not** identical to the SIL/PL values of the units that are used and may be different. We recommend that you use the PAScal software tool to calculate the safety function's SIL/PL values.

9 Supplementary data

9.1 Categories

9.1.1 Safety level

The maximum achievable safety level depends, among other things, on the sensor, the wiring and the operating mode of the PSSu K F EI CV(-T).



INFORMATION

The safety-related characteristic data of the PSSu K F EI CV(-T) and all other devices that are used must be taken into account when calculating the safety level. We recommend that you use the PAScal software tool to calculate the safety function's SIL/PL values.

The safety assessments below only consider the subsystems *Sensor* and PSSu K F EI CV(-T). The *Actuator* subsystem depends on the application and must also be considered in the overall assessment.

Information on the safety-related characteristic data for the subsystems *Sensor* and PSSu K F EI CV(-T)

Example:

Sensor subsystem			Subsystem PSSu K F EI CV(-T)	
Category	MTTFd	DC	Operating mode	PFH [1/h]
2	Manufacturer-specific	90 %	Monitoring 1 sensor	1,80E-08

The values for *Category* and *DC* can be set for the sensor subsystem, bearing in mind the restrictions stated in the respective chapter. The MTTFd value must be stated by the sensor manufacturer.

Assuming that all faults are dangerous, $MTTF = MTTFd$ can be set.

The characteristic value MTTF is a property of the sensor, which may only be stated by the manufacturer.

Forced dynamisation:

When monitoring sensors with square output signals (TTL, HTL) or safe sensors, the axis must be moved within 8 hours so that the signal changes on all the connected tracks.

9.1.2 Safety functions

The following safe monitoring functions are available:

- ▶ Safe Speed Monitoring (SSM)
- ▶ Safe Speed Range Monitoring (SSR-M)
- ▶ Safe Direction Monitoring (SDI-M)
- ▶ Safe Operating Stop Monitoring (SOS-M)
- ▶ Safe Stop 1 Monitoring (SS1-M)

- ▶ Safe Stop 2 Monitoring (SS2-M)
- ▶ Determination of the relative position for further evaluation in the user program (position counter value)

The safety functions of the PSSu K F EI CV(-T) are monitoring functions, whereby a safe output signal is used to show if defined limit values are exceeded.

The reaction function that takes place (e.g. shutting down the drive, activating a mechanical brake) when exceeded limit values are detected during the normal operation of the safety function must be defined and implemented by the machine/plant developer and does not form part of the PSSu K F EI CV(-T).

The monitoring function of the PSSu K F EI CV(-T) can be used to implement safety functions defined in the standard EN 61800-5-2 for Adjustable speed electrical power drive systems.

Safety functions in accordance with EN 61800-5-2	Implemented with monitoring function of the PSSu K F EI CV(-T)
Safe Operating Stop (SOS)	Safe Operating Stop Monitoring (SOS-M)
Safe Speed Range (SSR)	Safe Speed Range Monitoring (SSR-M)
Safe Direction (SDI)	Safe Direction Monitoring (SDI-M)
Safe Speed Monitoring (SSM)	Safe Speed Monitoring (SSM)
Safe Stop 1 (SS1)	Safe Stop 1 Monitoring (SS1-M)
Safe Stop 2 (Safe stop 2, SS2)	Safe Stop 2 Monitoring (SS2-M)

9.1.3 Safety-related characteristic data for operation with non-safety-related encoder without additional requirements

9.1.3.1 Permitted sensor types and output signals

Permitted encoder types:

- ▶ Rotary non-safety-related encoders
- ▶ Linear non-safety-related encoders

Permitted output signals:

- ▶ Square output signals TTL, single ended
- ▶ Square output signals TTL, differential
- ▶ Square output signals HTL, single ended
- ▶ Square output signals HTL, differential
- ▶ Sin/Cos output signals 1V_{ss}, reference voltage
- ▶ Sin/Cos output signals 1V_{ss}, differential

9.1.3.2 Safety-related architecture

To calculate the safety function you will need the following data for the "sensor" subsystem and the subsystem PSSu K F EI CV(-T):

Sensor			Subsystem PSSu K F EI CV(-T)	
Category	MTTFd	DC	Operating mode	PFH (1/h)
1*	Manufacturer-specific	0 %	Monitoring 1 sensor	1,80E-08

*In accordance with EN ISO 13849-1, Category 1 is only met if the sensor is a "well-tried component".

The values for **DC** refer to the standard EN 61508.

9.1.3.3 Achievable safety level

Monitoring function	PL of EN ISO 13849-1: 2015	SIL CL in accordance with EN IEC 62061
SOS-M	PL c (Cat.1)	-
SSR-M		
SDI-M		
SSM		
SS1-M		
SS2-M		
Position counter value		

9.1.4 Safety-related characteristic data for operation with non-safety-related encoder with mechanical fault exclusion

In accordance with EN 61800-5-2: 2007, Table D.16 (Motion and position feedback sensors), fault exclusions are permitted for faults in the mechanical connection between the sensor and motor.

9.1.4.1 Permitted sensor types and output signals

Permitted encoder types:

- ▶ Rotary non-safety-related encoders

Permitted output signals:

- ▶ Sin/Cos output signals 1Vss, reference voltage
- ▶ Sin/Cos output signals 1Vss, differential



NOTICE

The signal tracks Cos and Sin must be generated independently. This means that the sine and cosine signals in the encoder must be conducted in independent channels, from the optics to the interface.

The two signal tracks must not be generated by a common processor.

One signal may not be derived from the other signal via an electronic circuit.

9.1.4.2 Safety-related architecture

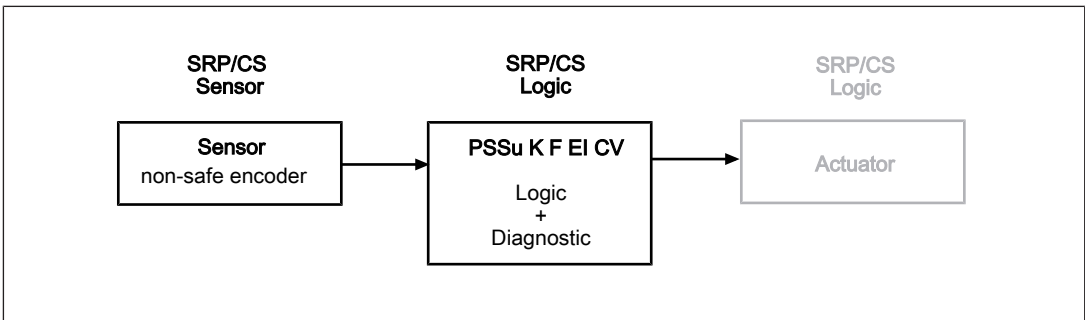

To calculate the safety function you will need the following data for the "sensor" subsystem and the subsystem "PSSu K F EI CV(-T)":

Sensor			Subsystem PSSu K F EI CV(-T)	
Category	MTTFd	DC	Operating mode	PFH (1/h)
2	Manufacturer-specific	90 %	Monitoring 1 sensor	1,80E-08

The values for **DC** refer to the standard EN 61508.

9.1.4.3 Achievable safety level

Monitoring function	PL of EN ISO 13849-1: 2015	SIL CL in accordance with EN IEC 62061
SOS-M	PL d (Cat.2)	2
SSR-M		
SDI-M		
SSM		
SS1-M		
SS2-M		
Position counter value		

9.1.5 Safety-related characteristic data for operation with non-safety-related encoder with diagnostics via the drive controller

The detection of sensor errors (diagnostics for the sensor subsystem via the evaluation device) can be supplemented with a drive controller.

9.1.5.1 Permitted sensor types and output signals

Permitted sensor types:

- ▶ Rotary non-safety-related encoders
- ▶ Linear non-safety-related encoders

Permitted output signals:

- ▶ Square output signals TTL, single ended
- ▶ Square output signals TTL, differential
- ▶ Square output signals HTL, single ended
- ▶ Square output signals HTL, differential
- ▶ Sin/Cos output signals 1V_{ss}, reference voltage
- ▶ Sin/Cos output signals 1V_{ss}, differential

9.1.5.2 Requirements of the drive controller

- ▶ Parameters for the control loops and motor control must be set in such a way as to guarantee stable operation.
Drag error detection (see below) must be capable of operating in accordance with the requirements of the safety function.
- ▶ The motor must be operated with a current impressing control procedure, based on the rotor position (field-oriented control). If the analogue track signals are idle, field-oriented control will brake and/or stop the rotor.
- ▶ The drive controller must be in position control operating mode.
- ▶ If a maximum error variable is exceeded (set/true comparison) the drive controller must switch to a fault condition and stop the drive (drag error detection). The error reaction to drag error detection should be a controlled motor stop.
- ▶ Fault detection via the error variable with subsequent shutdown must meet the requirements of the safety function, with regard to reaction times for example.
- ▶ The drive controller must evaluate the same incremental/SinCos signals from the encoder for control as are processed by the safe evaluation device (important on encoders with combined analogue/digital interface).

9.1.5.3 Safety-related architecture

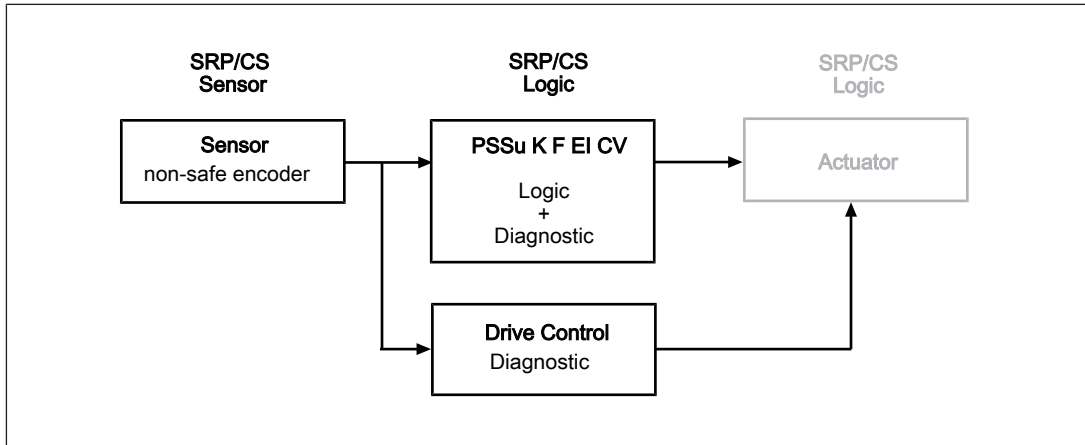

To calculate the safety function you will need the following data for the "sensor" subsystem and the subsystem "PSSu K F EI CV(-T)":

Sensor			Subsystem PSSu K F EI CV(-T)	
Category	MTTFd	DC	Operating mode	PFH (1/h)
2	Manufacturer-specific	90 %	Monitoring 1 sensor	1,80E-08

The values for **DC** refer to the standard EN 61508.

9.1.5.4 Achievable safety level

Monitoring function	PL of EN ISO 13849-1: 2015	SIL CL in accordance with EN IEC 62061
SOS-M	PL d (Cat.2)	2
SSR-M		
SDI-M		
SSM		
SS1-M		
SS2-M		
Position counter value		

9.1.6 Safety-related characteristic data for operation with a safe encoder

Safe encoders are certified in accordance with EN 61508, EN 13849 and EN 62061. In order to achieve the safety level stated by the encoder, the safe evaluation device (PSSu K F EI CV(-T)) must normally detect designated errors. Details of the safe encoder's requirements of the evaluation device can be found in the user documentation for the safe encoder. The encoder and evaluation device must be compatible.

9.1.6.1 Permitted sensor types and output signals

Permitted encoder types:

- ▶ Rotary safety-related encoders
- ▶ Linear safety-related encoders

Permitted output signals:

- ▶ Sin/Cos output signals 1Vss, reference voltage
- ▶ Sin/Cos output signals 1Vss, differential

9.1.6.2 Safety-related architecture

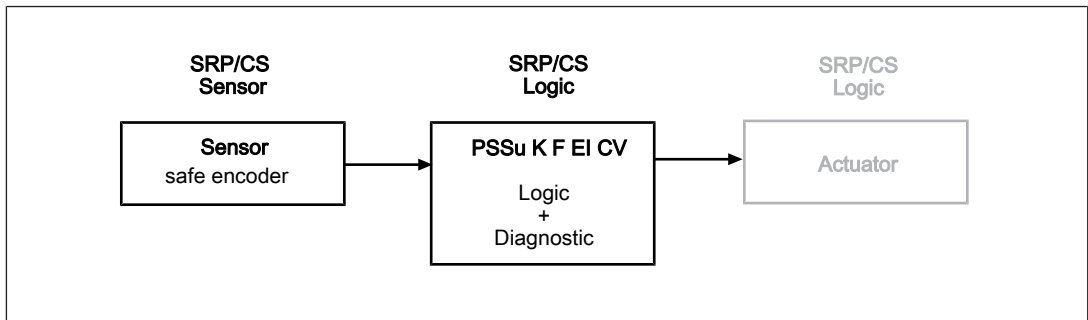

To calculate the safety function you will need the following data for the "sensor" subsystem and the subsystem "PSSu K F EI CV(-T)":

Sensor			Subsystem PSSu K F EI CV(-T)	
PL	SIL	PFH (1/h)	Operating mode	PFH (1/h)
See manufacturer			Monitoring Safe sensor	2,35E-09

9.1.6.3 Achievable safety level

Monitoring function	PL of EN ISO 13849-1: 2015	SIL CL in accordance with EN IEC 62061
SOS-M SSR-M SDI-M SSM SS1-M SS2-M	PL e (Cat.4)	3
Position counter value	PL d (Cat.2)	2

9.1.7 Safety-related characteristic data for operation with a safe encoder with Z index

Safe encoders are certified in accordance with EN 61508, EN 13849 and EN 62061. In order to achieve the safety level stated by the encoder, the safe evaluation device (PSSu K F EI CV(-T)) must normally detect designated errors. Details of the safe encoder's requirements of the evaluation device can be found in the user documentation for the safe encoder. The encoder and evaluation device must be compatible.

9.1.7.1 Permitted sensor types and output signals

Permitted encoder types:

- ▶ Rotary safety-related encoders
- ▶ Linear safety-related encoders

Permitted output signals:

- ▶ Square output signals TTL, differential with Z index
- ▶ Square output signals HTL, differential with Z index
- ▶ Sin/Cos output signals 1Vss, reference voltage with Z index
- ▶ Sin/Cos output signals 1Vss, differential with Z index

9.1.7.2 Safety-related architecture

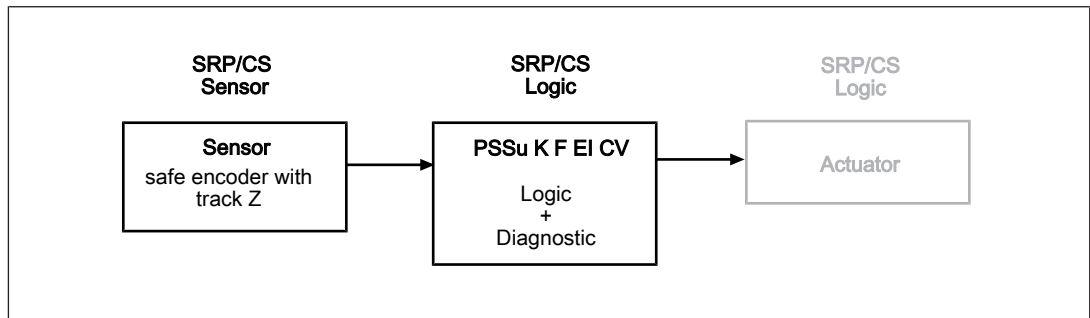

To calculate the safety function you will need the following data for the "sensor" subsystem and the subsystem "PSSu K F EI CV(-T)":

Sensor			Subsystem PSSu K F EI CV(-T)	
PL	SIL	PFH (1/h)	Operating mode	PFH (1/h)
See manufacturer			Monitoring 2 sensors	1,01E-09

9.1.7.3 Achievable safety level

Monitoring function	PL of EN ISO 13849-1: 2015	SIL CL in accordance with EN IEC 62061
SOS-M SSR-M SDI-M SSM SS1-M SS2-M	PL e (Cat.4)	3
Position counter value	PL d (Cat.2)	2

9.1.8 Safety-related characteristic data for operation with non-safety-related encoder and proximity switch

The speed monitoring of the non-safety-related encoder can be verified via an additional reference sensor.

9.1.8.1 Permitted sensor types and output signals**Non-safety-related encoder**

Permitted encoder types:

- ▶ Rotary non-safety-related encoders
- ▶ Linear non-safety-related encoders

Permitted output signals:

- ▶ Square output signals TTL, single ended
- ▶ Square output signals TTL, differential
- ▶ Square output signals HTL, single ended
- ▶ Square output signals HTL, differential
- ▶ Sin/Cos output signals 1Vss, reference voltage
- ▶ Sin/Cos output signals 1Vss, differential

Reference sensor

Permitted encoder types:

- ▶ Rotary non-safety-related encoders
- ▶ Linear non-safety-related encoders
- ▶ Inductive proximity switches

Permitted output signals:

- ▶ Square output signals HTL, single ended
- ▶ Square output signal 24 V, pnp

9.1.8.2 Safety-related architecture

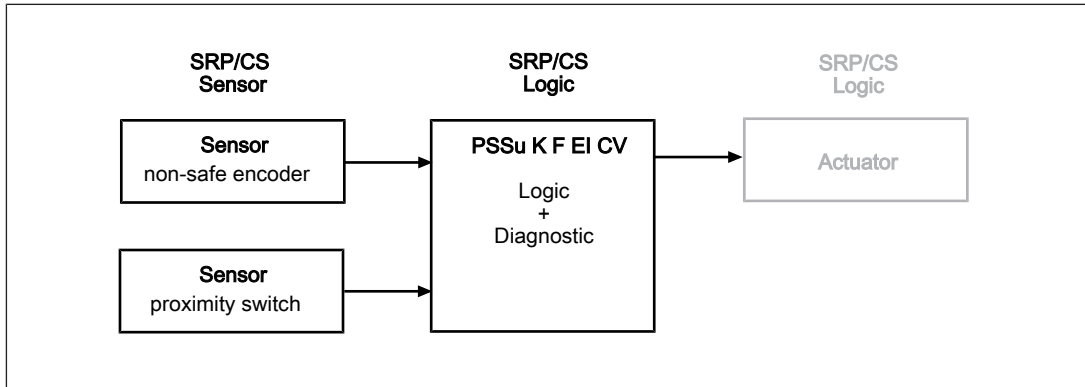

To calculate the safety function you will need the following data for the "sensor" subsystem and the subsystem "PSSu K F EI CV(-T)":

Sensor			Subsystem PSSu K F EI CV(-T)	
Category	MTTFd	DC	Operating mode	PFH (1/h)
4	Manufacturer-specific	90 %	Monitoring 2 sensors	1,01E-09

In a worst case scenario, the sensor subsystem's characteristic value MTTFd is calculated from the inferior (lower) value of the two sensors.

9.1.8.3 Achievable safety level

Monitoring function	PL of EN ISO 13849-1: 2015	SIL CL in accordance with EN IEC 62061
SOS-M SDI-M SS2-M Position counter value	PL c (Cat.1)	-
SSR-M SSM SS1-M	PL e (Cat.4)	3

Please note:

For the "sensor" subsystem, a minimum speed must be exceeded within forced dynamisation.

The minimum speed depends on the ratio of the frequency at tracks AB " f_{AB} " to the frequency at track Z " f_Z " in your configuration and is calculated as follows:

- ▶ when $f_{AB}/f_Z \text{ Verh.} \geq 1.0$
 $f_Z = 10 \text{ mHz}$ or $f_{AB} = (f_{AB}/f_Z) \times 10 \text{ mHz}$
- ▶ when $f_{AB}/f_Z \text{ Verh.} < 1.0$
 $f_{AB} = 10 \text{ mHz}$ or $f_Z = 10 \text{ mHz}/(f_{AB}/f_Z)$

At the very latest, a feasibility error will be detected when a tolerance expires. The tolerance level depends on the ratio of the frequency at tracks AB " f_{AB} " to the frequency at track Z " f_Z " in your configuration (**f_{AB}/f_Z Verh.** setting in the menu) and is calculated as follows:

- ▶ when **f_{AB}/f_Z Verh.** ≥ 1.0
7.5 Z-pulses or $7.5 \times (f_{AB}/f_Z)$ AB-pulses
- ▶ when **f_{AB}/f_Z Verh.** < 1.0
4.5 AB-pulses or $4.5/(f_{AB}/f_Z)$ Z-pulses

9.1.9 Safety-related characteristic data for operation with 2 proximity switches

9.1.9.1 Permitted sensor types and output signals

Non-safety-related sensor

Permitted output circuits:

- ▶ pnp
- ▶ npn

9.1.9.2 Safety-related architecture

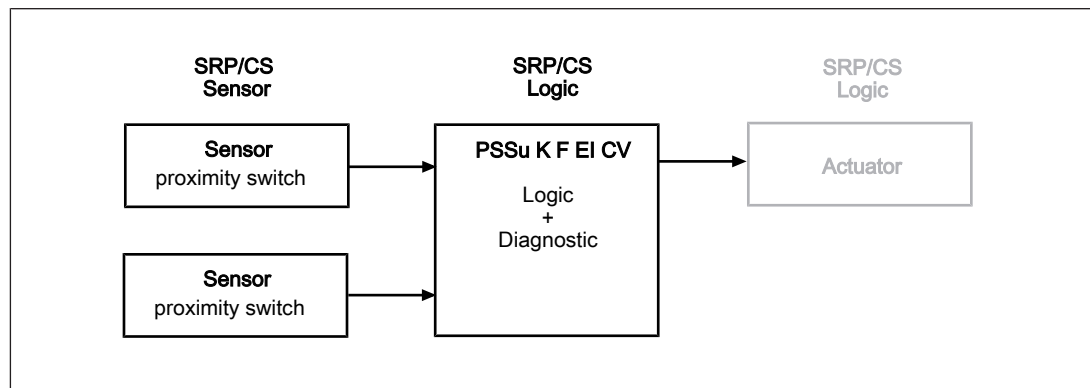

To calculate the safety function you will need the following data for the "sensor" subsystem and the subsystem "PSSu K F EI CV(-T)":

Sensor			Subsystem PSSu K F EI CV(-T)	
Category	MTTFd	DC	Operating mode	PFH (1/h)
4	Manufacturer-specific	90 %	Monitoring 2 sensors	1,01E-09

In a worst case scenario, the sensor subsystem's characteristic value MTTFd is calculated from the inferior (lower) value of the two sensors.

9.1.9.3 Achievable safety level

Monitoring function	PL in accordance with EN ISO 13849-1: 2015	SIL CL in accordance with EN IEC 62061
SSR-M SSM	PL e (Cat.4)	3

Please note:

Common cause failures (CCF) are possible for the sensor subsystem. An appropriate analysis must be carried out.

To use proximity switches 1 and 2 we recommend that you:

- ▶ Use different technologies/design or physical principles (e.g. different manufacturers) and
- ▶ Evaluate the sensor supply via track S

10 Order reference

10.1 Product

Product type	Features	Order no.
PSSu K F EI CV	Compact module, base type	312 434
PSSu K F EI CV-T	Compact module, T-type	314 434

10.2 Accessories

Terminals

Product type	Features	Order no.
PSSu A Con Set1 C	Set consisting of connectors with spring-loaded terminals 1-row/5-pin and 1-row/10-pin, scope of supply: 2 pieces	313 114

Labelling

Product type	Features	Order no.
PSSu A LC 0.2	Labelling bracket, scope of supply: 5 pieces	312 965
PSSu A LA0	Labelling strips, laser printable, scope of supply: 1080 pieces (10 x DIN A4 sheet, 108 on each)	312 958

Adapter cable

Product type	Features	Order no.
MM A MINI-IO CAB99	1.50 m	772 200
MM A MINI-IO CAB99	2.50 m	772 201
MM A MINI-IO CAB99	5.0 m	772 202